

# VACUUM EQUIPMENT FOR ULTRA HIGH VACUUM APPLICATIONS

**EDWARDS**



A close-up photograph of an Edwards NEXT ultra-high vacuum pump. The pump is a compact, rectangular metal device with a complex, multi-faceted design. It features a prominent cooling fin structure on the right side and a control panel on the front. The control panel includes three indicator lights labeled 'Normal', 'Status', and 'Alarm', and the Edwards logo (a stylized 'E' with a red arc) and the word 'NEXT' printed below it. The background is a blurred industrial setting with other similar components.

# EDWARDS THE PARTNER OF CHOICE

With almost 100 years' experience Edwards has grown to be the market leader in vacuum technology offering a complete range of vacuum pumps from atmosphere to ultra-high vacuum.

Our extensive range of products and expertise in the field means you can trust us to provide a complete solution for your ultra high vacuum application. This brochure contains the most common Edwards products for UHV applications. There are many more products available via our product catalogue, website or by contacting your local Edwards sales representative.

# CONTENTS

## 05 VACUUM PRODUCTS FOR UHV APPLICATIONS

Ultra high vacuum pumps

---

## 36 MEASUREMENT AND CONTROL

Pressure measurement and display options

---

## 44 LEAK DETECTION AND MEASUREMENT

Leak detection solution

---

## 46 SERVICE - SOLUTIONS

Cost-effective service and support from the experts

---



## Our UHV products

We offer a broad range of products suitable for a wide range of UHV applications. Having revolutionised the dry vacuum pump in 1984, Edwards has led the technological advancement of dry vacuum pump innovation for more than 30 years. Our dry pumps have become the industry standard due to their high reliability, performance capabilities and serviceability.

For applications requiring high vacuum our comprehensive range of hybrid bearing and magnetically levitated turbomolecular pumps are available with pumping speeds from 47 to 4300  $\text{ls}^{-1}$ .

When a ready to go UHV pumping solution is required, we have a range of turbomolecular pumping stations, combining a backing pump, turbomolecular pump and controller into a compact package; or our unique single-shaft regenerative and Holweck primary pump which operates from atmosphere to  $10^{-6}$  mbar in a single unit.

Gamma capture pumps from Edwards are specifically designed for ultra-high vacuum applications, and available with specially modified elements that extend the range of application to meet the lowest possible pressures in the extreme high vacuum range. In order to reach ultra-high vacuum, a leak tight system is essential. Our new ELD500 precision leak detector has a class leading sensitivity with the ability to measure leaks as small as  $5 \times 10^{-12}$  mbar  $\text{ls}^{-1}$ .

We also offer a full set of instruments for measuring pressures from atmospheric down to extreme high vacuum.

# Vacuum products for UHV applications

	nXDS/XDS Dry Scroll Pumps	nEXT Turbomolecular Pumps	Turbomolecular Pumping Stations	STP Maglev Turbomolecular Pumps	EPX High Vacuum Primary Pump	Ion Getter Pumps	Titanium Sublimation Pumps	Non-Evaporable Getter Pumps	Measurement and Control	Leak Detection and Measurement
Page number	6/10	14	18	22	26	28	31	32	36	44
Application										
Angle Resolved Photoemission Spectroscopy (ARPES)	•	•	•	•	•	•	•	•	•	•
Atom Probe Tomography (APT)	•	•	•	•	•	•	•	•	•	•
Atomic Force Microscopy	•	•	•	•	•	•	•	•	•	•
Auger Electron Spectroscopy (AES)	•	•	•	•	•	•	•	•	•	•
Beamlines	•	•	•	•	•	•	•	•	•	•
Cyclotrons	•	•	•	•	•	•	•	•	•	•
Electron Microscopy	•	•	•	•	•	•	•	•	•	•
Field Emission Microscopy (FEM)	•	•	•	•	•	•	•	•	•	•
Field Ion Microscopy (FIM)	•	•	•	•	•	•	•	•	•	•
Gravitational Wave Detectors	•	•	•	•	•	•	•	•	•	•
Linear Accelerators (LINAC)	•	•	•	•	•	•	•	•	•	•
Lithography	•			•	•				•	•
Molecular Beam Epitaxy (MBE)	•			•	•	•	•		•	•
Particle Accelerators/Colliders	•	•	•	•	•	•	•	•	•	•
Process Growth				•					•	•
Proton Beam Therapy	•	•	•	•	•	•	•	•	•	•
Scanning Tunneling Microscopy	•	•	•	•	•	•	•	•	•	•
Secondary Ion Mass Spectroscopy (SIMS)	•	•	•	•	•	•	•	•	•	•
Surface Science (Other)	•	•	•	•	•	•	•	•	•	•
Synchrotron Storage Rings	•	•	•	•	•	•	•	•	•	•
Thermal Desorption Spectroscopy (TPD)	•	•	•	•	•	•	•	•	•	•
X-ray Imaging	•	•	•	•	•	•	•	•	•	•
X-ray Photoelectric Spectroscopy (XPS)	•	•	•	•	•	•	•	•	•	•

# nXDS DRY SCROLL PUMPS



With exceptional pumping capability, even for light gases and extremely low ultimate pressure, the nXDS dry scroll pump is the best backing pump for UHV applications in its class.

nXDS improves on other scroll pumps by offering increased pumping speeds, combined with lower ultimate pressures, low power consumption and reduced noise. The gas ballast allows for pumping of condensable vapours, helping to remove the water vapour due to outgassing.

nXDS pumps feature the very latest in tip seal technology, giving a significantly longer life between tip seal changes. nXDS-R has the gas ballast blanked off so it cannot be accidentally opened. This is useful for applications such as rare gas recirculation or gas recovery.

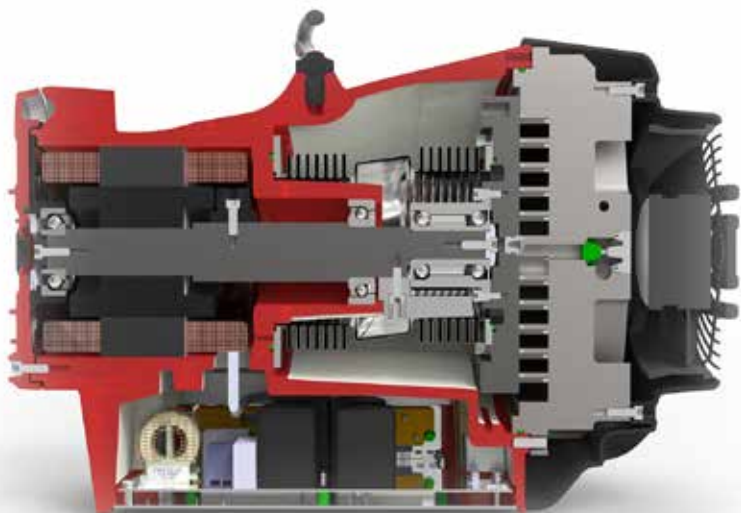

## PRODUCT FEATURES

### TEMPERATURE CONTROLLED FAN

Allows reduced fan speed under low load conditions for reduced acoustic noise from only 52 dB(A).

### BEARING SHIELD

Ensures separation between process gases and bearing lubrication to ensure clean vacuum and no possibility of contamination to lubrication from process gases, which prolongs bearing life.

### INVERTER DRIVE

Means consistent performance globally, ease of control, lower power consumption and automatic voltage adjustment delivering the ultimate in user experience.

### ENHANCEMENTS IN SCROLL DESIGN

Deliver higher speeds and a decade lower ultimate pressures than first generation scroll pumps with ultimate from only  $7 \times 10^{-3}$  mbar

### IMPROVED TIP SEAL TECHNOLOGY

Delivers a step change in life, with a typical tip seal life of more than 2 years on most applications.

### HIGH FLOW GAS BALLAST FEATURE

Allows pumping of vapours including water vapour at up to  $220 \text{ gh}^{-1}$ .

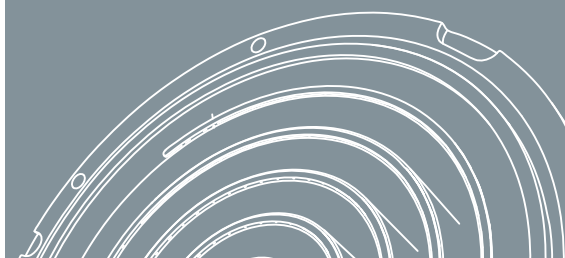

## Technical data

	Units	nXDS6i	nXDS10i	nXDS15i	nXDS20i
<b>Vacuum data</b>					
Peak pumping speed	m <sup>3</sup> h <sup>-1</sup> (cfm)	6.2 (3.6)	11.4 (6.7)	15.1 (8.9)	22.0 (13.0)
Ultimate vacuum <sup>(1)</sup>	mbar (Torr)	0.02 (0.015)	0.007 (0.005)		0.03 (0.022)
Ultimate vacuum with gas ballast	mbar (Torr)	0.05 (0.038)	0.04 (0.03)		0.06 (0.045)
Water vapour tolerance	mbar (Torr)	35 (26)			20 (15)
Water vapour handling capacity	gh <sup>-1</sup>	110	145	240	220
Maximum continuous inlet pressure <sup>(2)</sup>	mbar a (Torr a)	200 (150)			50 (38)
Maximum gas ballast/purge pressure	bar gauge (psig)	0.5 (7)			
<b>Motor data</b>					
Supply voltage	V	100-127/200-240 (+/-10%)			
Supply frequency	Hz	50/60			
Nominal rotational speed	rpm	1800			
Minimum standby rotational speed	rpm	1200			
Speed control resolution	%	1			
Power at ultimate	W	260	280	300	260
Motor power	W	660			
Power connector		IEC EN60320 C13			
Recommended fuse, 230 V (115 V)	A	10 (13)			
<b>Physical data</b>					
Weight	kg (lb)	26.2 (58)	25.8 (57)	25.2 (56)	25.6 (56)
Inlet connection		NW25			
Exhaust connection		NW25			
Noise level at ultimate	dB(A)	52			
Noise level with acoustic enclosure	dB(A)	47			
Vibration at inlet flange	mms <sup>-1</sup> (rms)	< 4.5			
Leak tightness (static)	mbar ls <sup>-1</sup>	< 1 x 10 <sup>-6</sup>			
Operating temperature range	°C (°F)	10 to 40 (50 to 104)			

(1) Measured as total pressure.

(2) These pumps are designed to pump down from atmospheric pressure, but prolonged operation at inlet pressures higher than specified may reduce bearing life.



# nXDS DRY SCROLL PUMPS

## Dimensions

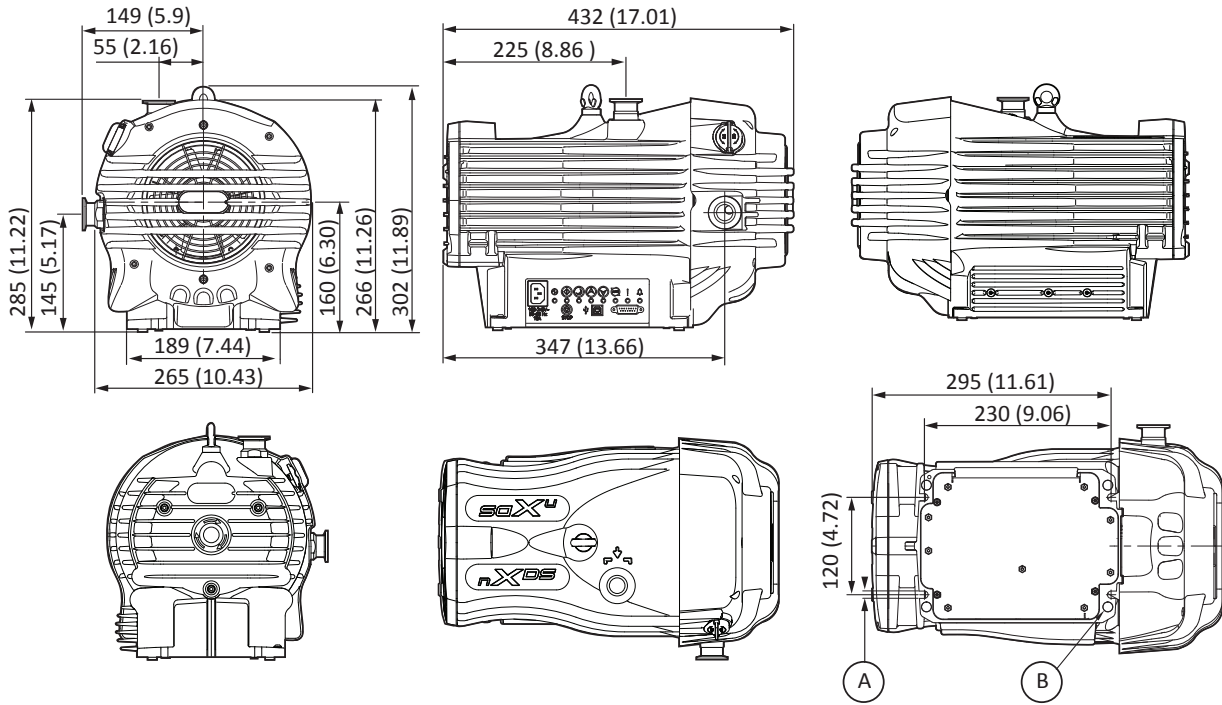

All nXDS variants are the same physical size  
Dimensions in millimetres (inches)

A. (4x) 9 mm wide slots  
B. (4x) Rubber feet

## Performance

### nXDS6i

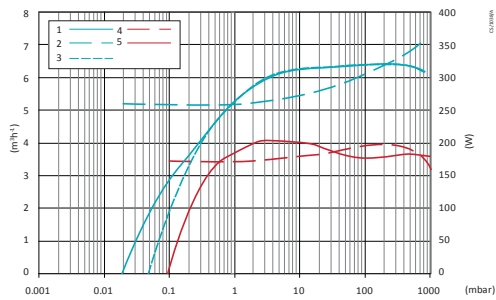

### nXDS10i

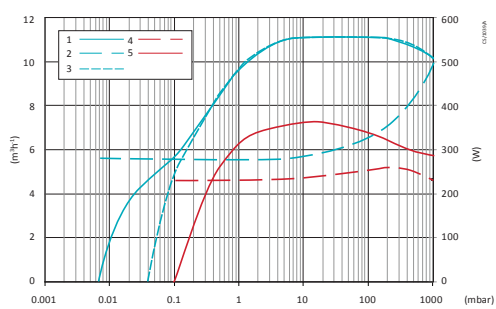

### nXDS15i

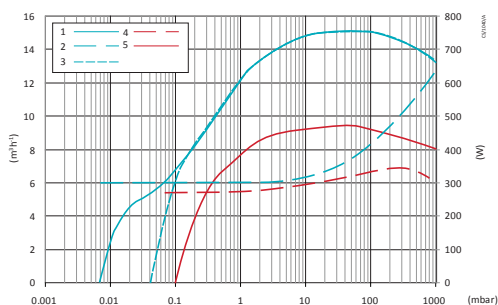

### nXDS20i

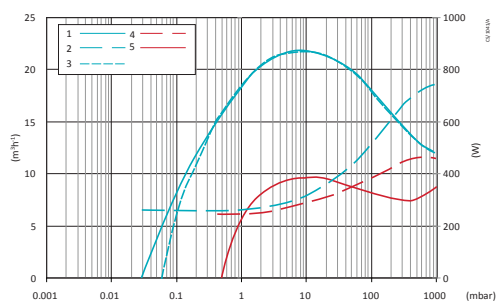

1. Normal pumping speed
2. Normal full power
3. Normal GB speed
4. Min standby power
5. Min standby speed



## Ordering information

Pumps:

Product description	Order number	
Standard product	nXDS6i	A73501983
	nXDS10i	A73601983
	nXDS15i	A73701983
	nXDS20i	A73801983
Variants without gas ballast (R)	nXDS6iR	A73503983
	nXDS10iR	A73603983
	nXDS15iR	A73703983
	nXDS20iR	A73803983

Extended warranty:

Product	2 year	3 year
nXDS6i	EW2AA5001	EW3AA5001
nXDS10i	EW2AA5002	EW3AA5002
nXDS15i	EW2AA5003	EW3AA5003
nXDS20i	EW2AA5004	EW3AA5004

Accessories and spares:

Product description	Order number	
Accessories	TIC (Turbo) 200 W	D39712000
	TIC (Turbo and Instruments) 200 W	D39722000
	Inlet/exhaust filter NW25	A50597805
	Gas ballast adaptor blank	A73501806
	Gas ballast adaptor with 0.25 mm restrictor	A73501809
	Gas ballast adaptor with no restrictor	A73501811
	Silencer NW25	A50597000
	Vibration isolators (pack of 4)	A24801441
	Acoustic enclosure 110-120 V	NRY5C0000
	Acoustic enclosure 200-240 V	NRD797000
Spares	Tip seal kit	A73501801
	Bearing replacement kit <sup>(1)</sup>	A73501802
	Exhaust and ballast valve kit (standard and R version)	A73501803
	Inlet/exhaust filter spares - 5 micron element	A50597802
	Inlet/exhaust filter spares - 1 micron element	A50597803
	Silencer spares kit	A50597800
	Cooling fan	A73501707
Cord sets	Gas ballast control knob	A73501059
	UK, three pin plug	A50505000
	North European plug	A50506000
	North American plug	A50507000
No plug	A50508000	

(1) Tooling and training required.



nXDS with common accessories

# XDS DRY SCROLL PUMPS



XDS dry scroll pumps have become the industry standard when dry pumping is essential, proving to be a robust and clean vacuum pump solution in a range of UHV applications. The XDS35i pump has an innovative bearing shield that isolates the vacuum environment from all forms of lubricant, making it not only lubricant-free but hermetically sealed.

XDS35iNGB variant has had the gas ballast feature removed for applications such as rare gas recirculation and gas recovery.

The XDS46i shares many of the same features of the XDS35i but with a peak speed of  $40 \text{ m}^3\text{h}^{-1}$ . The pump has been optimised for maximum pumping speed at inlet pressures between 1 mbar and 10 mbar, making it ideally suited for backing turbomolecular pumps.



## PRODUCT FEATURES

### BEARING SHIELD

Ensures separation between process gases and bearing lubrication to ensure clean vacuum and no possibility of contamination to lubrication from process gases, which prolongs bearing life.

### INVERTER DRIVE

Means consistent performance globally, pump overload protection and remote start/stop capability.

### HIGH FLOW GAS BALLAST FEATURE

Allows pumping of vapours including water vapour at up to  $240 \text{ gh}^{-1}$ .

### UNIQUE AXIAL AIR GAP MOTOR

Reduces overall pump size and gives low power and noise.

### SIMPLE SINGLE SIDED SCROLL DESIGN

Allows maintenance to be done in minutes for low cost of ownership and maximum up-time.

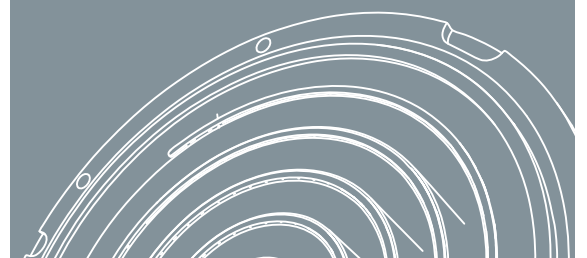

## Technical data

	Units	XDS35i	XDS46i
<b>Vacuum data</b>			
Peak pumping speed	m <sup>3</sup> h <sup>-1</sup> (cfm)	35 (21)	40 (23.5)
Ultimate vacuum <sup>(1)</sup>	mbar (Torr)	0.01 (0.008)	0.05 (0.04)
Ultimate vacuum with gas ballast 1	mbar (Torr)	0.02 (0.015)	0.08 (0.06)
Ultimate vacuum with gas ballast 2	mbar (Torr)	< 10 (7.5)	
Max inlet pressure for water vapour	mbar (Torr)	35 (23)	40 (30)
Water vapour handling capacity GBII	gh <sup>-1</sup>	240	
Maximum continuous inlet pressure <sup>(2)</sup>	mbar a (Torr a)	40 (30)	
Maximum gas ballast/purge pressure	bar gauge (psig)	0.5 (7)	
<b>Motor data</b>			
Supply voltage	V	100-120/200-240 (+/- 10%)	
Supply frequency	Hz	50/60	
Nominal rotation speed	rpm	1750	
Power at ultimate	W	440	380
Motor power	W	520	
Power connector		IEC EN60320 C19	
Recommended fuse, 230 V (115 V)	A	16 <sup>(3)</sup> (20)	
<b>Physical data</b>			
Weight	kg (lb)	48 (105)	
Inlet connection		NW40	
Exhaust connection		NW25	
Noise level at ultimate	dB(A)	57	55.4
Noise level with acoustic enclosure	dB(A)	48	46.4
Vibration at inlet flange	mms <sup>-1</sup> (rms)	< 4.5	
Leak tightness (static)	mbar ls <sup>-1</sup>	< 1 x 10 <sup>-6</sup>	
Operating temperature range	°C (°F)	5 to 40 (41 to 104)	

(1) measured as total pressure

(2) These pumps are designed to pump down from atmospheric pressure, but prolonged operation at inlet pressures higher than specified may reduce bearing life.

(3) for UK 240 V use 13 A fuse



# XDS DRY SCROLL PUMPS

## Dimensions

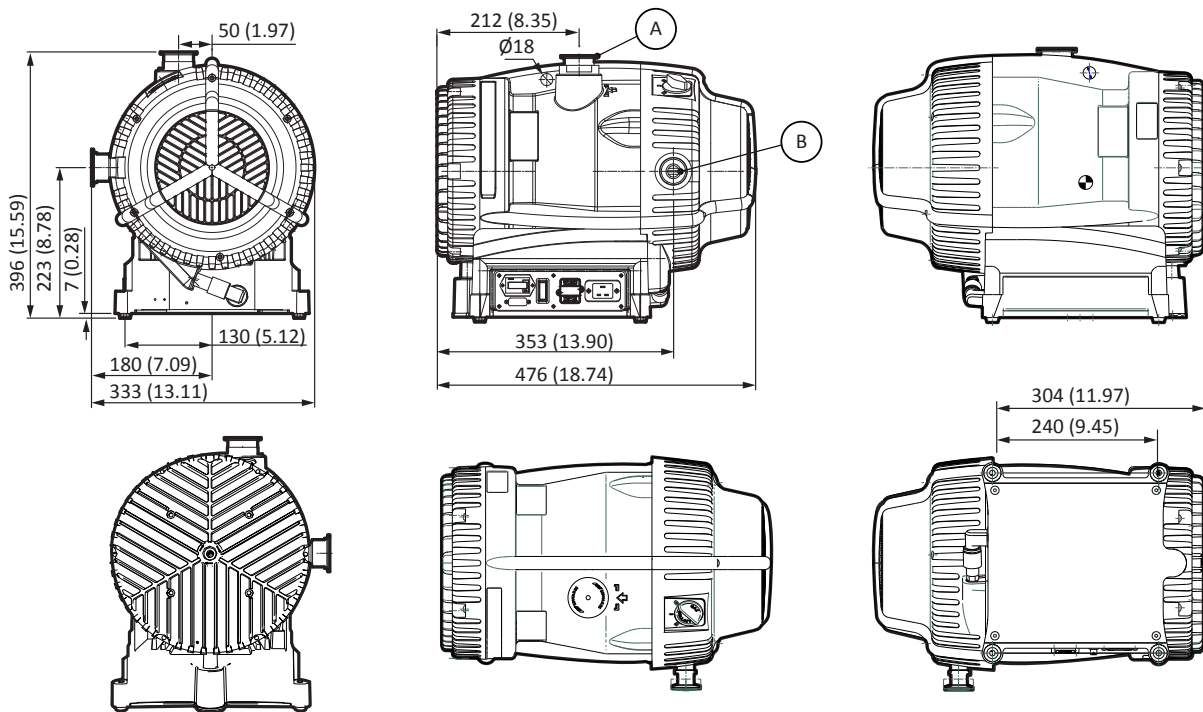

A. NW40  
B. NW25

## Performance

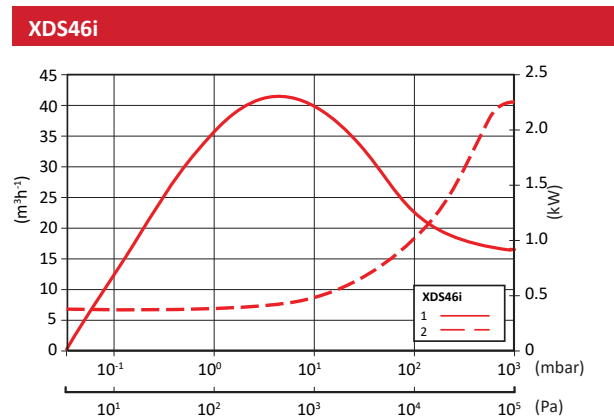
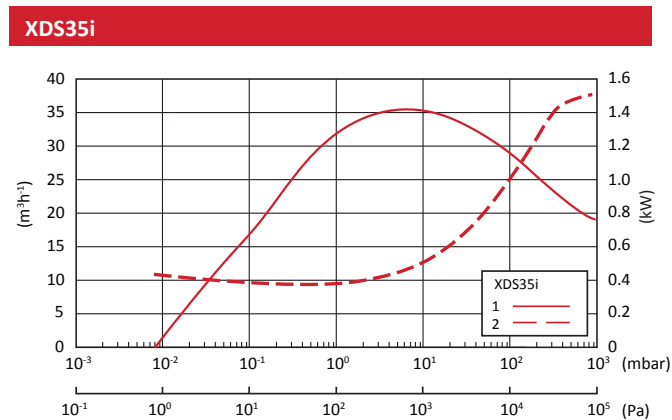

1. Speed  
2. Power

## Ordering information

Pumps:

Product description		Order number
Standard product	XDS35i	A73001983
	XDS46i	A73101983
Variants without gas ballast (NGB)	XDS35i-NGB	A73005983

Extended warranty:

Product	2 year	3 year
XDS35i	EW2AA5005	EW3AA5005
XDS46i	EW2AA5006	EW3AA5006

Accessories and spares:

Product description		Order number
Accessories	Exhaust silencer XDS35i	A50597001
	Gas ballast adaptor with 0.25 mm restrictor	A50626801
	Gas ballast adaptor with no restrictor	A50502000
	Vibration isolator (pack of 4)	A24801408
	Inlet/exhaust filter NW25	A50597805
	Inlet/exhaust filter NW40	A50597806
	XDS acoustic enclosure 110-120 V	NRY5C0000
Spares	XDS acoustic enclosure 200-240 V	NRD797000
	Tip-seal kit XDS35i	A73001801
	Tip-seal kit XDS46i	A73101801
	Silencer spares kit	A50597801
	XDS filter 5 micron element kit	A50597802
	XDS filter 1 micron element kit	A50597803
	Cord sets	UK, three pin plug
North European plug		A50506003
North America/Japan plug		A50507003
No plug		A50508003

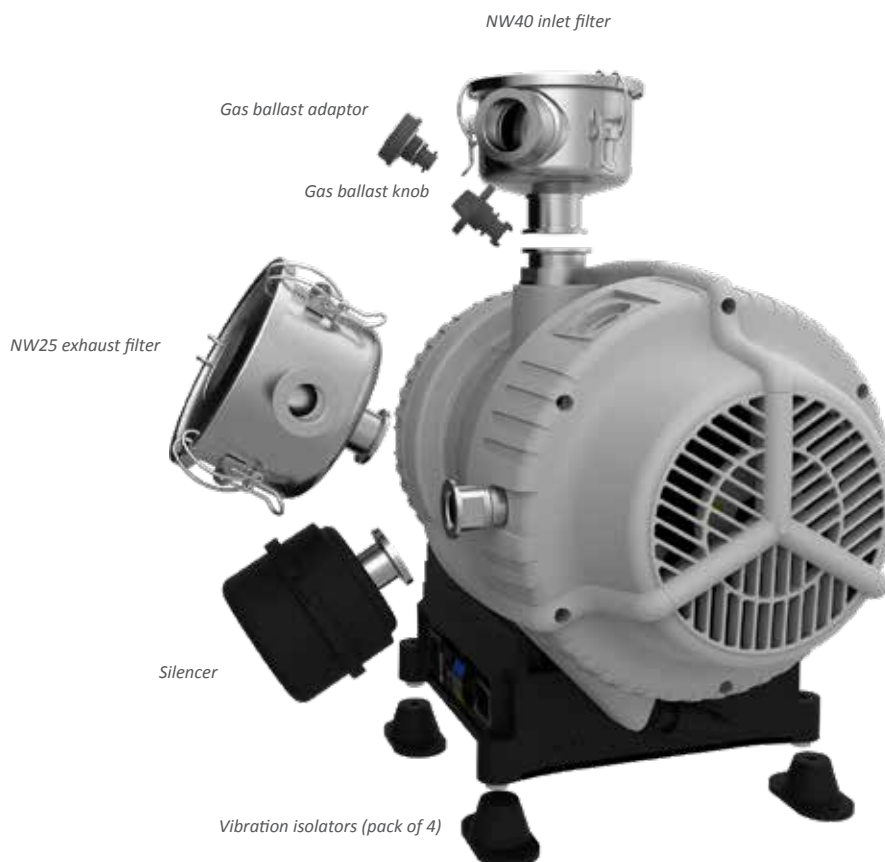

# nEXT TURBOMOLECULAR PUMPS



nEXT turbomolecular pumps are hybrid bearing pumps with a compound drag stage and integrated controllers for pumping speeds from 47 to 400  $\text{ls}^{-1}$ .

They all feature a permanent magnetic upper bearing, which eliminates hydrocarbons at the top of the rotor and an oil lubricated lower bearing for reliable high speed operation.

Optimised rotor design means nEXT pumps deliver on both speed and compression making them ideal for UHV applications. The on-board controller interfaces directly with our TIC and TAG controllers to provide low cost system integration. nEXT pumps also allow user serviceability by way of a user changeable bearing cartridge for low cost of ownership.



*nEXT300 turbomolecular pump shown*

## PRODUCT FEATURES

### UPPER MAGNETIC BEARING

Ensures clean vacuum, low power and low vibration.

### INLET SCREEN

Supplied as standard (prevents large items from getting into the pump).

### OPTIMISED ROTOR DESIGNS

Deliver high speeds and high compression.

### RANGE OF VARIANTS SUITABLE FOR MANY APPLICATIONS

D = standard nEXT pump variant.

H = optimised rotor design for high light gas compression

T = additional regenerative stage for increased compression and higher backing pressure capability.

### MANUAL VENT VALVE

Offers a safe place to vent system with no risk of damage to pump and can be replaced with a solenoid valve for fully automated venting.

### INTEGRATED CONTROLLER

Offers direct I/O or serial control or can be connected to one of our TAG or TIC controllers for easy systemisation.

### FULLY USER-SERVICEABLE

Oil cartridge and bearings can be changed in the field with minimal tooling.

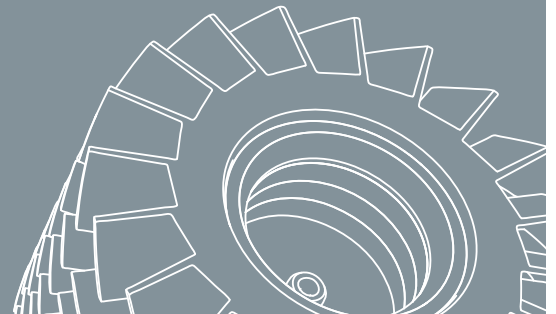

## Technical data

		Units	nEXT85 DN40	nEXT85 DN63	nEXT240	nEXT300	nEXT400
<b>Vacuum data</b>							
Peak pumping speed	N <sub>2</sub>	ls <sup>-1</sup>	47	84	240	300	400
	Ar		44	80	230	280	380
	He		61	78	230	340	390
	H <sub>2</sub>		49/44 (D/H)	60/54 (D/H)	165	280	325
Compression ratio	N <sub>2</sub>		> 10 <sup>11</sup>		> 10 <sup>11</sup> (D&T)		
	Ar		> 10 <sup>11</sup>		> 10 <sup>11</sup> (D&T)		
	He		8 x 10 <sup>6</sup> /2 x 10 <sup>7</sup> (D/H)		3 x 10 <sup>5</sup> /10 <sup>6</sup> (D/T)	10 <sup>6</sup> /3 x 10 <sup>6</sup> (D/T)	10 <sup>8</sup> / <sup>&gt;</sup> 10 <sup>8</sup> (D/T)
	H <sub>2</sub>		2 x 10 <sup>5</sup> /5 x 10 <sup>5</sup> (D/H)		10 <sup>4</sup> /10 <sup>5</sup> (D/T)	5 x 10 <sup>4</sup> /10 <sup>5</sup> (D/T)	5 x 10 <sup>5</sup> /10 <sup>6</sup> (D/T)
Ultimate vacuum (CF)		mbar	<5 x 10 <sup>-10</sup>				
Maximum backing pressure	N <sub>2</sub>	mbar	18		9.5/20 (D/T)		
<b>Motor data</b>							
Maximum power consumption		W	80 (range 50 - 120)		160 (range 50 - 200)		
Operating voltage		V d.c.	24 - 48				
Nominal rotational speed		rpm	90,000		60,000		
<b>Physical data</b>							
Weight (ISO/CF)		kg	3	3/4.5	6/9		7/10
Inlet connection			NW40	ISO63 or CF63	ISO100 or CF100		ISO160 or CF160
Backing connection			NW16		NW25		
Magnetic field tolerance		mT	5				
Run-up time		secs	115		145	175	
Orientation of installation			Flange upright through to horizontal +/- 2°				
Cooling method			Ambient/air/water				
Maximum system flange temperature during bakeout (CF only)			Water cooled/forced air cooled 120/115°C				
Bearing technology			Permanent magnetic upper; oil lubricated ceramic lower				
User-serviceable bearings			Yes				
Controller type			Integrated				
Interfaces			RS232, 485, I/O				
Optional interfaces			External Profibus				



nEXT85



nEXT240



nEXT300



nEXT400

## Dimensions

nEXT85

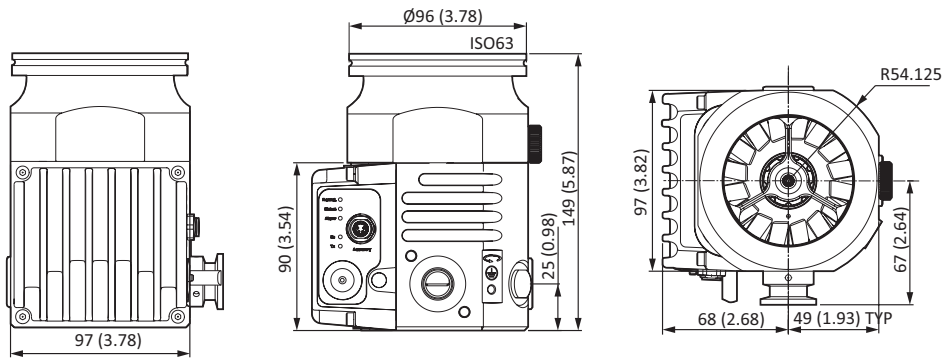

nEXT240/300/400

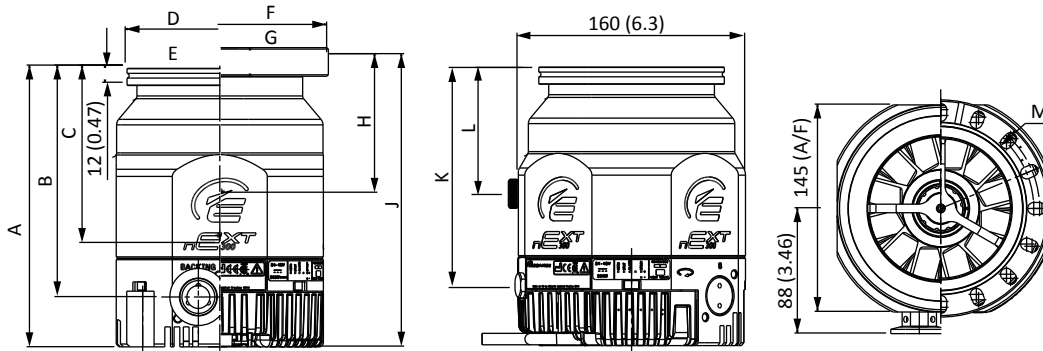

	nEXT240	nEXT300	nEXT400
A	189	195	195
B	155	160	160
C (C of G)	116	117	102
D	130	130	180
E	ISO100	ISO100	ISO160
F	152	152	202

	nEXT240	nEXT300	nEXT400
G	CF100	CF100	CF160
H (C of G)	90	100	81
J	197	210	200
K	147	153	153
L	83	87	89
M	(16) $\varnothing 8.4$	(16) $\varnothing 8.4$	(20) $\varnothing 8.4$

## Performance

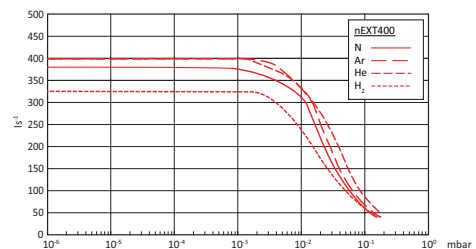
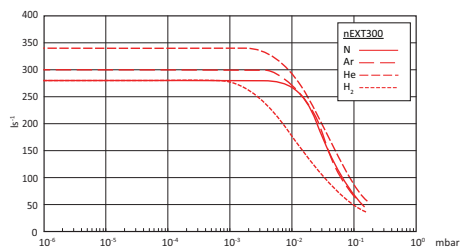
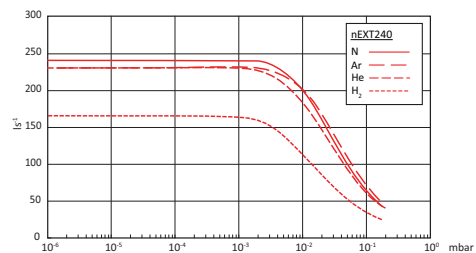
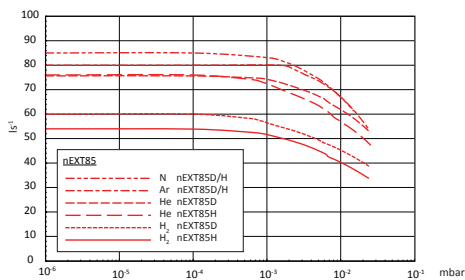



## Ordering information

Pumps:

Product description	Order number
nEXT85D NW40	B8G210A01
nEXT85D ISO63	B8G210B01
nEXT85D CF63	B8G210C01
nEXT85H NW40	B8G410A01
nEXT85H ISO63	B8G410B01
nEXT85H CF63	B8G410C01
nEXT240D ISO100 160W	B81200100
nEXT240D CF100 160W	B81200200
nEXT240T ISO100 160W	B81300100
nEXT240T CF100 160W	B81300200
nEXT300D ISO100 160W	B82200100
nEXT300D CF100 160W	B82200200
nEXT300T ISO100 160W	B82300100
nEXT300T CF100 160W	B82300200
nEXT400D ISO160 160W	B83200300
nEXT400D CF160 160W	B83200400
nEXT400T ISO160 160W	B83300300
nEXT400T CF160 160W	B83300400

Extended warranty:

Warranty extension (total)	Order number
nEXT85 2 year	EW2AA5093
nEXT85 3 year	EW3AA5093
nEXT240 2 year	EW2AA5008
nEXT240 3 year	EW3AA5008
nEXT300 2 year	EW2AA5009
nEXT300 3 year	EW3AA5009
nEXT400 2 year	EW2AA5010
nEXT400 3 year	EW3AA5010

Accessories and spares:

Pump	Product description	Order number	
nEXT85	Controller <sup>(1)</sup>	TAG controller	D39592000
		TAG power supply	D39592800
		TIC100 turbo and instrument controller	D39721000
	Cooling	WCX85 water cooling kit (4 position)	B8G200833
		ACX85 air cooler connector fitted	B8G200820
	Venting	N/O TAV5 vent valve connector fitted	B8G200834
		N/C TAV5 vent valve connector fitted	B8G200835
	Bakeout	CF63 flange heater 110 V	B8G200823
		CF63 flange heater 240 V	B8G200824
	Service	Bearing replacement kit	B8G200827
		Oil cartridge kit	B8G200828
		Bearing and oil cartridge kit	B8G200811
	Miscellaneous	Bearing replacement tool kit	B8G200845
		Accessory "Y" adaptor	B8G200837
	nEXT240/ 300/400	Controller <sup>(1)</sup>	Accessory cable 90° / extension
TAG controller			D39592000
TAG power supply			D39592800
Cooling		TIC200 turbo and instrument controller	D39722000
		nEXT radial air cooler	B58053175
		nEXT axial air cooler	B58053185
Bakeout		nEXT water cooler	B80000815
		CF100 100-120 V flange heater	B58052773
		CF100 200-240 V flange heater	B58052774
		CF160 100-120 V flange heater	B58052775
Venting		CF160 200-240 V flange heater	B58052776
		TAV5 solenoid operated vent valve	B58066010
Service		Oil cartridge tool kit	B80000812
		Bearing tool kit	B80000805
		Oil cartridge	B80000811
All	Extension cables	Bearing and oil cartridge	B80000810
		1 m pump to controller cable	D39700835
		3 m pump to controller cable	D39700836
	Power cables <sup>(1)</sup>	5 m pump to controller cable	D39700837
		2 m electrical supply cable UK plug	D40013025
		2 m electrical supply cable EU plug	D40013030
	Miscellaneous	2 m electrical supply cable US plug	D40013120
		Vent port adaptor	B58066011
		PRX10 purge restrictor	B58065001

(1) Denotes required accessory. Others optional depending on application.



# T-STATION 85 TURBOMOLECULAR PUMPING STATION



Our T-Station 85 is a low cost, compact turbomolecular pumping station that seamlessly combines an nEXT85H turbomolecular pump with either a dry diaphragm or oil sealed backing pump, and a simple controller, providing pumping speeds of 47 to 84  $\text{ls}^{-1}$ .

The T-Station 85 comes with an integrated Turbo and Active Gauge controller which enables single button start/stop of the system. With the ability to control one of our active gauges, vent valve control and delayed start of the turbomolecular pump to either time or pressure if a gauge is fitted, makes the T-Station 85 ideal for a variety of UHV applications.



## PRODUCT FEATURES

### CUSTOM INTEGRATED CONTROLLER FEATURES:

Single dedicated button to start/stop pumps; Easy to read accurate display; Ability to select vent mode where a TAV5 vent valve is fitted for automated venting with no user intervention.

### HIGH CAPACITY BACKING PUMPS

E2M1.5 or XDD1 high capacity backing pumps giving the choice between an oil sealed pump or a totally dry diaphragm pump.

### COMPACT LOW PROFILE

Base plate includes rubber feet and cut-outs in the sides for manual handling, giving a compact low profile but stable design that cannot be knocked over.

### USER SERVICEABLE

The nEXT85 turbomolecular pump, XDD1 dry diaphragm pump and E2M1.5 backing pump are all user serviceable.

### INTEGRATED AIR COOLER

Acts to cool internal power supply and pump/controller for quiet operation avoiding multiple fans.

### RUGGED METAL FRAME

All metal frame means rugged design that can take abuse without cracking or breaking.

### INLET FLANGE OPTIONS

Available with either an NW40, ISO63 or CF63 inlet flange to suit your application.



## Dimensions

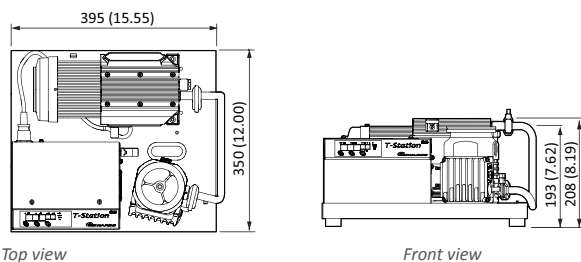

Top view

Front view

T-Station 85D with XDD1 backing pump

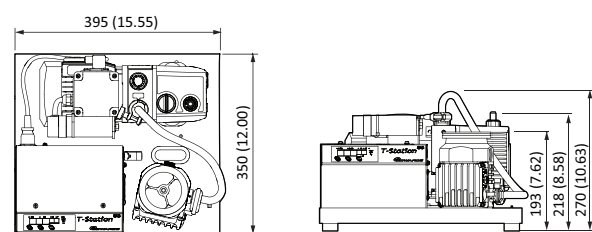

Top view

Front view

T-Station 85W with E2M1.5 backing pump

## Ordering information

Pumping station:

Product description	Order number
T-Station 85H Wet NW40 200-240V	TS85W1001
T-Station 85H Wet ISO63 200-240V	TS85W2001
T-Station 85H Wet CF63 200-240V	TS85W3001
T-Station 85H Dry NW40 200-240V	TS85D1001
T-Station 85H Dry ISO63 200-240V	TS85D2001
T-Station 85H Dry CF63 200-240V	TS85D3001
T-Station 85H Wet NW40 100-120V	TS85W1002
T-Station 85H Wet ISO63 100-120V	TS85W2002
T-Station 85H Wet CF63 100-120V	TS85W3002
T-Station 85H Dry NW40 100-120V	TS85D1002
T-Station 85H Dry ISO63 100-120V	TS85D2002
T-Station 85H Dry CF63 100-120V	TS85D3002

## Technical data

T-Station 85		
Pumping speed for N <sub>2</sub>	NW40	47 ls <sup>-1</sup>
	ISO/CF63	84 ls <sup>-1</sup>
Compression ratio for N <sub>2</sub>		>1 x 10 <sup>11</sup>
Backing pump speed, 50 Hz (60 Hz)	E2M1.5 (TS85W)	1.6 m <sup>3</sup> h <sup>-1</sup> (1.2 cfm)
	XDD1 (TS85D)	1.2 m <sup>3</sup> h <sup>-1</sup> (0.9 cfm)
Ultimate vacuum (CF)		<5 x 10 <sup>-10</sup> mbar
Inlet connection		NW40, ISO63 or CF63
Exhaust connection	E2M1.5 (TS85W)	11mm OD nozzle or 3/8" BSP
	XDD1 (TS85D)	Fitted silencer or 1/8" BSP
Weight	E2M1.5 system (TS85W)	21 kg max
	XDD1 system (TS85D)	17 kg max
Noise level at ultimate		≤56 dB(A)
Leak tightness (static)		<1 x 10 <sup>-6</sup> mbar ls <sup>-1</sup>
Operating temperature range		12 to 40 °C

Accessories, spares and extended warranty:

	Product description	Order number
Accessories	EMF3 mist filter for E2M1.5	A46220000
	N/O TAV5 vent valve connector fitted	B8G200834
	N/C TAV5 vent valve connector fitted	B8G200835
	APG100 XLC NW16 Pirani Gauge	D02603000
	AIM X NW25 Inverted Magnetron Gauge	D14642000
	WRG-S NW25 Wide Range Gauge	D14701000
	APGX-H NW25 Convection Gauge	D02391000
Cord sets	2 m electrical supply cable UK plug	A50505000
	2 m electrical supply cable EU plug	A50506000
	2 m electrical supply cable North America/Japan plug	A50507000
	2m electrical supply cable no plug	A50508000
	0.5 m Gauge cable	D40001005
Warranty	1 m Gauge cable	D40001010
	T-Station 85 2 year total warranty extension	EW2AA5094
	T-Station 85 3 year total warranty extension	EW3AA5094

# nEXT TURBOMOLECULAR PUMPING STATIONS



nEXT turbomolecular pumping stations are configurable with turbomolecular pump speeds ranging from 47 to 400  $\text{ls}^{-1}$  and a choice of oil sealed or dry backing pumps ranging from 1 to 20  $\text{m}^3\text{h}^{-1}$ .

All our nEXT turbomolecular pumping stations feature an integrated TIC turbo and instrument controller offering full control of the package via a simple intuitive interface.

The nEXT turbomolecular pumping stations are supplied fully assembled and ready to run straight out of the box and include common accessories such as mist filters and mains cables as appropriate to the chosen pumps.

As fully featured high end stations they include RS232 serial communications and Windows® software for monitoring and control.



## PRODUCT FEATURES

### RANGE OF TURBOMOLECULAR PUMP OPTIONS

Choice of turbomolecular pump with speeds ranging from 47 to 400  $\text{ls}^{-1}$  and inlet flanges from DN40 to DN160.

### FULLY CONTROLLABLE

TIC turbo and instrument controller offers full control of pumps and up to 3 Active gauges as well as offering full serial remote communications.

### VENT VALVE OPTION

Optional turbomolecular pump vent valve can be ordered as part of cart assembly.

### USER SERVICEABLE

All nEXT turbomolecular pumps and backing pumps are fully user serviceable.

### ROBUST METAL FRAME

All metal frame with locking castors for a robust but easily mobile system. Bench mounting kit included for safe bench top operation.

### CHOICE OF BACKING PUMPS

Choice of oil sealed and dry backing pumps with capacities ranging from 1 to 20  $\text{m}^3\text{h}^{-1}$ .

### LOW VIBRATION

Backing pump mounted on anti-vibration mounts for low levels of transmitted vibration.

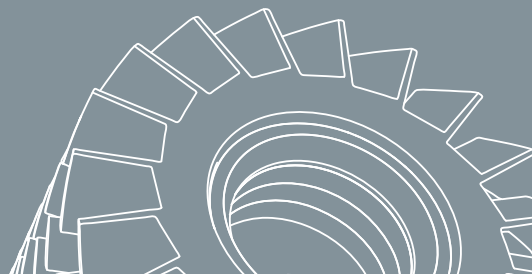

## Dimensions

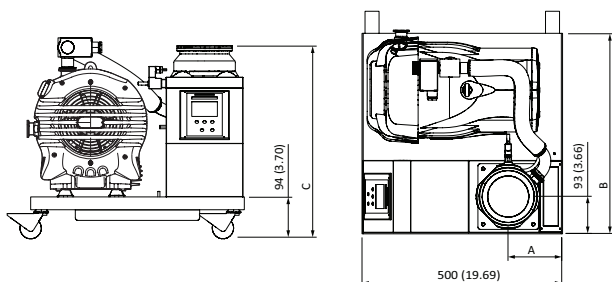

	A	B <sup>(1)</sup>	C
nEXT85 NW40	144	380/500	427
nEXT85 ISO63	144	380/500	401
nEXT85 CF63	144	380/500	415
nEXT240 ISO100	135.5	380/500	443.2
nEXT240 CF100	135.5	380/500	451.2
nEXT300 ISO100	135.5	380/500	448.7
nEXT300 CF100	135.5	380/500	463.2
nEXT400 ISO160	135.5	380/500	448.7
nEXT400 CF160	135.5	380/500	453.7

(1) 380 mm refers to small platforms with XDD1/E2M1.5 backing pumps  
500 mm refers to large platforms with nXDS/RV backing pumps

## Technical data

nEXT Turbo Station		
Peak pumping speed for N <sub>2</sub>	NW40	47 ls <sup>-1</sup>
	ISO/CF63	84 ls <sup>-1</sup>
	ISO/CF100	240 or 300 ls <sup>-1</sup>
	ISO/CF160	400 ls <sup>-1</sup>
Compression ratio for N <sub>2</sub>		>1 x 10 <sup>11</sup>
Backing pump speed, 50 Hz (60 Hz)	E2M1.5	1.6 m <sup>3</sup> h <sup>-1</sup> (1.2 cfm)
	RV	5.1 m <sup>3</sup> h <sup>-1</sup> (3.6 cfm)
	RV12	12 m <sup>3</sup> h <sup>-1</sup> (8.4 cfm)
	XDD1	1.2 m <sup>3</sup> h <sup>-1</sup> (0.9 cfm)
	nXDS6i	6.2 m <sup>3</sup> h <sup>-1</sup> (3.6 cfm)
	nXDS10i	11.4 m <sup>3</sup> h <sup>-1</sup> (6.7 cfm)
	nXDS15i	15.1 m <sup>3</sup> h <sup>-1</sup> (8.9 cfm)
nXDS20i	22 m <sup>3</sup> h <sup>-1</sup> (13.0 cfm)	
Ultimate vacuum (CF)		<5 x 10 <sup>-10</sup> mbar
Inlet connection		NW40, ISO63, CF63, ISO100, CF100, ISO160 or CF160
Exhaust connection	E2M1.5	NW16
	XDD1	Fitted silencer or 1/8" BSP
	RV/nXDS	NW25
Weight	E2M1.5/XDD1	24.9 to 35 kg
	RV/nXDS	41.2 kg to 55 kg
Noise level at ultimate		≤ 56 dB(A)
Leak tightness (static)		<1 x 10 <sup>-6</sup> mbar ls <sup>-1</sup>
Operating temperature range		12 to 40 °C

Accessories:

Product description	Order number
APG100 XLC NW16 Pirani Gauge	D02603000
AIM X NW25 Inverted Magnetron Gauge	D14642000
WRG-S NW25 Wide Range Gauge	D14701000
APGX-H NW25 Convection Gauge	D02391000
0.5 m Gauge cable	D40001005
1 m Gauge cable	D40001010

## Ordering information

Pumping station:

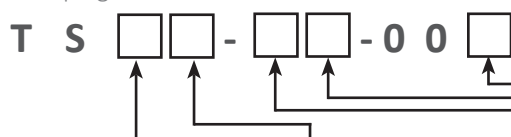

B nEXT240D	1 DN40NW (nEXT85)	1 E2M1.5	0 Manual Vent	1 220-240 V 50/60 Hz (Europe)
C nEXT300D	2 DN63ISO-K (nEXT85)	2 RV5	1 TAV5 Vent Valve	2 110-120 V 50/60 Hz (USA)
D nEXT400D	3 DN63CF (nEXT85)	3 RV12		3 200 V 50/60 Hz (Japan)
E nEXT240T	4 DN100ISO-K (nEXT240/300)	A XDD1		4 220-240 V 50/60 Hz (UK)
F nEXT300T	5 DN100CF (nEXT240/300)	D nXDS6i		
G nEXT400T	6 DN160ISO-K (nEXT400)	E nXDS10i		
J nEXT85D	7 DN160CF (nEXT400)	F nXDS15i		
K nEXT85H		G nXDS20i		

# STP MAGLEV TURBOMOLECULAR PUMPS

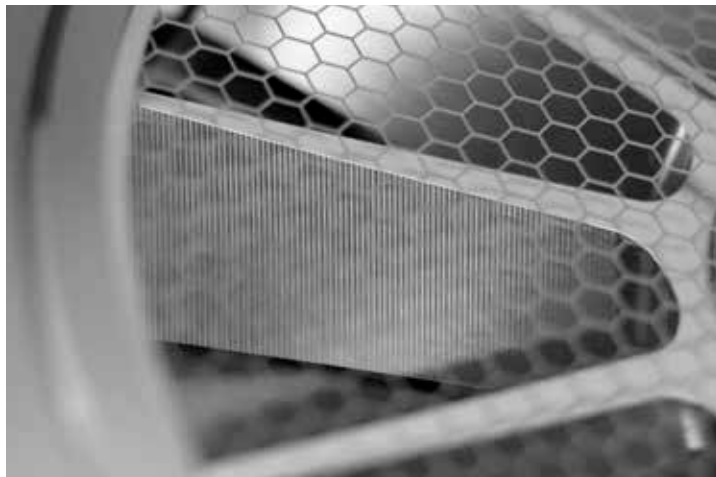

STP maglev turbomolecular pumps are the first choice for applications demanding high up-time, hydrocarbon-free pumping, minimal maintenance and low vibration. The multi-axis magnetic bearing system is used to suspend the rotor during operation, ensuring there is no risk of contamination while minimising noise and vibration.

The STP maglev turbomolecular pump range has a market leading reputation for quality and reliability and are the preferred choice for many of the most challenging High Energy Physics applications. For UHV applications this makes STP maglev turbomolecular pumps extremely reliable and normally maintenance free.



## PRODUCT FEATURES

### VIBRATION FREE

Magnetic levitation means no friction and thus extremely low vibration, in addition this remains constant and does not change as parts wear.

### OIL FREE

The use of magnetic bearings eliminates all hydrocarbon lubricants.

### AUTOMATIC BALANCING SYSTEM

Edwards 5-axis pumps are able adjust the magnetic field dynamically to take out rotor imbalances.

### MAINTENANCE FREE

Zero friction means no wear and thus no routine maintenance is required in normal operation.

### RADIATION RESISTANCE

Models with an external controller offer radiation resistance of up to  $10^5$  rads where higher radiation resistance is required. We offer an enhanced range with up to  $10^7$  rads resistance on request.

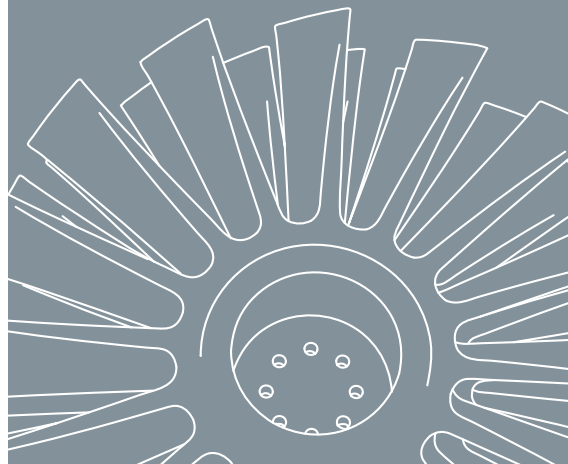

## Technical data

		Units	STP301 DN100	STP451 DN160	STP603 DN160	STP1003 DN200	STPiX457 DN100	STPiX457 DN160	STPiX3006 DN250	STPiX3006 DN320	
<b>Vacuum data</b>											
Pumping speed	N <sub>2</sub>	ls <sup>-1</sup>	300	480	650	1000	300	450	2300	2700	
	H <sub>2</sub>		300	460	550	800	300	460	2600	2700	
Compression ratio	N <sub>2</sub>	>10 <sup>8</sup>									
	H <sub>2</sub>	2 x 10 <sup>4</sup>			>10 <sup>5</sup>			1 x 10 <sup>4</sup>		6x10 <sup>4</sup>	
Ultimate vacuum (CF)		mbar	<1 x 10 <sup>-10</sup>						<1 x 10 <sup>-9</sup>		
Maximum flow rate	N <sub>2</sub>	sccm	-				120		1000		
Maximum inlet pressure		mbar	6.7 x 10 <sup>-4</sup>		1.3 x 10 <sup>-4</sup>		1.3 x 10 <sup>-3</sup>		-		
Maximum backing pressure		mbar	0.13				0.67		1.33		
<b>Motor data</b>											
Maximum power consumption		W	350		800		240		1500		
Nominal rotational speed		rpm	48,000		35,000		55,000		27,000		
<b>Physical data</b>											
Weight		kg	11	12	31		16		84	87	
Vibration		µm	<0.01				<0.005				
Inlet connection			ISO100 or CF100	ISO160 or CF160	ISO160 or CF160	ISO200 or CF200	ISO100 or CF100	ISO160 or CF160	ISO250 or CF250	ISO320 or CF320	
Backing connection			NW25		NW40		NW25		NW40		
Run-up time		secs	180		360		480		840		
Magnetic field tolerance axial/radial		mT	15/3								
Orientation of installation			Any								
Cooling method			Ambient/Air/Water				Ambient/Air		-		
Maximum flange temperature during bakeout (CF only)		°C	120								
Bearing technology			3 axis magnetically levitated			5 axis magnetically levitated					
Controller type			External				Integrated				
Power supply type			External						-		
Interfaces			RS232, I/O								
Optional interfaces			Profibus		Profibus, EtherCAT						



STP301



STP451



STP603



STP1003



STPiX457



STPiX3006

## Dimensions

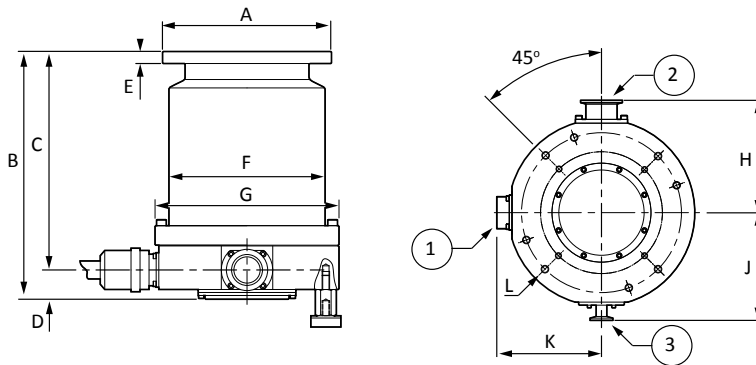

Note: STP603 pump shown

1. Electrical connector
2. Outlet port
3. Purge port

	A	B	C	D	E	F	G	H	J	K	L
STP301	Ø130 ISO100	230	197	33	12	Ø156	Ø180	108	110	100	8 x M8 x 16
	Ø152 DN100CF				22						
STP451	Ø180 ISO160	200	167	33	12	Ø208	Ø245	148	142	138	8 x M10 x 24
	Ø203 DN160CF				22						
STP603	Ø225 ISO160F	330	291	39	16	Ø208	Ø245	148	142	138	8 x M10 x 24
	Ø203 DN160CF				22						
STP1003	Ø285 ISO200F	310	271	89	16	Ø152	Ø180	108	124	101	4 x M10 x 18
	Ø253 DN200CF				25						
STPiX457	Ø130 ISO100	286	197	89	12	Ø152	Ø180	108	124	101	4 x M10 x 18
	Ø152 DN100CF				22						
	Ø180 ISO160	256	167	89	12	Ø152	Ø180	108	124	101	4 x M10 x 18
	Ø203 DN160CF				22						
STPiX3006	Ø335 ISO250F	435	322	113	15	Ø335	Ø358	210	182	150	6 x M16 x 30
	Ø305 DN250CF	440	327		28						
	Ø425 ISO320F	396	283		20						

## Performance

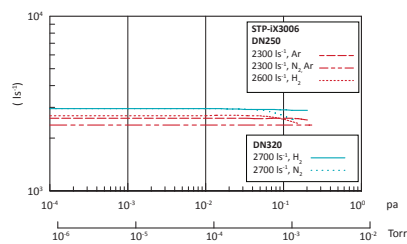
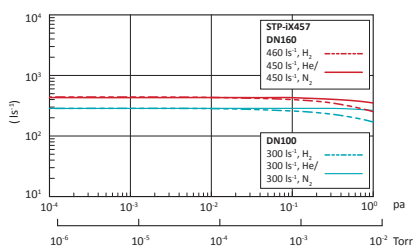
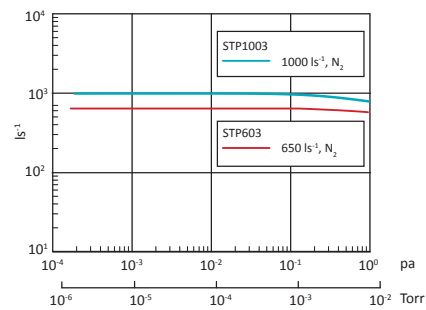
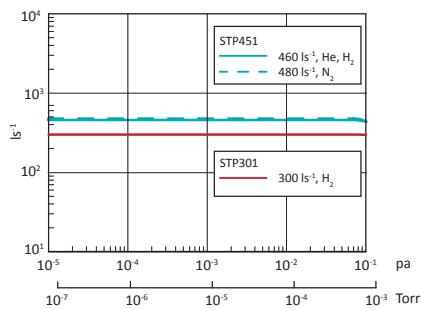



## Ordering information

### Pumps:

Product description	Order number
<b>STP301</b>	
STP301 ISO100	YT21B0350
STP301 CF100	YT21B0010
<b>STP451</b>	
STP451 ISO160	YT21B0460
STP451 CF160	YT21B0080
<b>STPiX457 without cooling</b>	
STPiX457 ISO100	YT860Z120
STPiX457 CF100	YT860Z150
STPiX457 ISO160	YT860Z130
STPiX457 CF160	YT860Z160
<b>STPiX457 with air cooling</b>	
STPiX457 ISO100	YT865Z000
STPiX457 CF100	YT865Z070
STPiX457 ISO160	YT865Z020
STPiX457 CF160	YT865Z080
<b>STP603</b>	
STP603 ISO160	YT39B0030
STP603 CF160	YT390Z005
<b>STP1003</b>	
STP1003 ISO200	YT390Z001
STP1003 CF200	YT39B0010
<b>STPiXR3006</b>	
STPiX3006 ISO250	YT830Z010
STPiX3006 CF250	YT830Z050
STPiX3006 ISO320	YT830Z030
STPiX3006 CF320	TBA

### Extended warranty:

Product description	3 year extension
STP301	EW3AA0127
STP451	EW3AA0129
STP603	EW3AA0135
STP1003	EW3AA0137
STPiX457	EW3AA0257
STPiX3006	EW3AA0244

Total 3 year warranty  
(including 1 year extension)

### Accessories and spares:

Pump		Product description	Order number	
STP301/451	Controller <sup>(1)</sup>	SCU350 100-240V	YT21Z0Z01	
		SCU350 100-240V with RS232	YT21ZEZ20	
	Pump to controller cables <sup>(1)</sup>	3m cable	B70700010	
		5m cable	B70700000	
		10m cable	B70700130	
		20m cable	B70700150	
		30m cable	PT21Y0B00	
	Mains cables <sup>(1)</sup>	3m	B70700090	
		5m	B70700040	
		10m	PT21Y0A00	
	Cooling	115V air cooler	YT011A003	
		220-240V air cooler	YT011A005	
Water cooling kit		YT21CA001		
STPiX457	Power supply with display <sup>(1)</sup>	iPD240 AC power supply 240V	YT86W0Z00	
	Pump to power supply cables <sup>(1)</sup>	2.5m cable	YT86Y0B15	
		5m cable	YT86Y0B20	
		10m cable	YT86Y0B30	
		15m cable	YT86Y0B40	
		20m cable	YT86Y0B50	
	Mains cables <sup>(1)</sup>	3m	PT64Y1A10	
		5m	PT64Y1A20	
		10m	PT64Y1A30	
	Vent valve*	Vent valve	YT860T211	
STP603/1003	Controller <sup>(1)</sup>	SCU800 100-120/200-240V with RS232/485	YT49Z2Z00	
	Pump to controller cables <sup>(1)</sup>	3m cable	B75130050	
		5m cable	B75130020	
		10m cable	B75130060	
		20m cable	B75130190	
		30m cable	B75130210	
	Mains cables <sup>(1)</sup>	3m	PT49Y0A05	
		5m	PT49Y0A00	
		10m	PT49Y0A01	
	Cooling	100-115V air cooler	YT01BA210	
		220-240V air cooler	YT011A020	
		Water cooling kit	YT170A001	
	STPiX3006	Display unit	iDT001 with 3m cable	YT79U1Z00
			iDT001 with 5m cable	YT79U1Z40
			iDT001 with 10m cable	YT79U1Z50
iDT001 with 15m cable			YT79U1Z10	
Mains cables <sup>(1)</sup>		3m	YT79Y0A01	
	5m	YT79Y0A00		
	10m	YT79Y0A03		
All	Bakeout	CF100 100-120 V flange heater	B58052773	
		CF100 200-240 V flange heater	B58052774	
		CF160 100-120 V flange heater	B58052775	
		CF160 200-240 V flange heater	B58052776	

\* Only 1 accessory can be controlled by the pump, so if fitting both air cooler and vent valve we recommend fitting vent valve to pump and using a mains air cooler

(1) denotes required accessory, others are optional depending on application.

# EPX HIGH VACUUM PRIMARY PUMP



The EPX series uses a unique, patented, single-shaft regenerative and Holweck® stage mechanism that makes them capable of pumping from atmosphere to ultimate pressures of  $<1 \times 10^{-4}$  mbar or  $<1 \times 10^{-6}$  mbar depending on model.

They are ideal for applications where a better base pressure is required than can be delivered by a typical primary pump and when used as a backing pump enable much lower UHV pressures to be achieved. They are also suitable for applications that cycle frequently from atmosphere to low pressures as they can operate continuously at all inlet pressures.

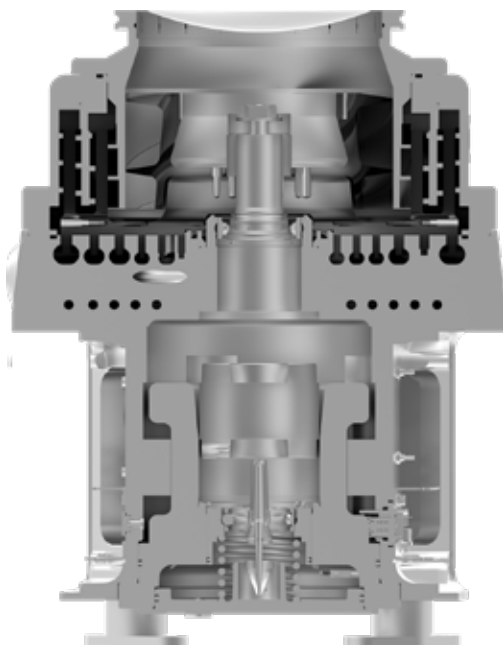

## PRODUCT FEATURES

### HOLWECK AND REGENERATIVE STAGES

For wide range performance with low heat and vibration.

### ADDITIONAL HELICAL ROTOR STAGE (EPX500 ONLY)

For increased speed and  $1 \times 10^{-6}$  mbar capability.

### COMPACT FOOTPRINT

EPX is smaller than the equivalent turbomolecular pump and primary pump combination.

### ULTRA CLEAN MECHANISM

EPX pumps have no oil or grease under vacuum and present no other source of potential contamination.

### WATER COOLED

For a low environmental heat load.

### NITROGEN PURGE FACILITY (N VARIANTS)

Which makes them suitable for pumping vapours and low levels of corrosive vapours and particulates.

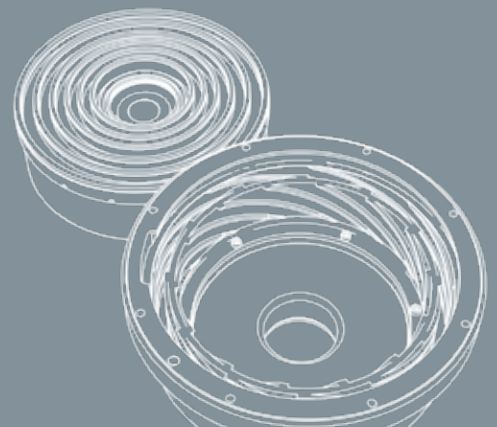

## Technical data

	Units	EPX180LE	EPX180NE	EPX500LE	EPX500NE
Peak pumping speed	m <sup>3</sup> h <sup>-1</sup> (cfm) [ls <sup>-1</sup> ]	175 (106) [50]		500 (295) [140]	
Ultimate vacuum	mbar (Torr)	<1 x 10 <sup>-4</sup> (<7 x 10 <sup>-5</sup> )		<1 x 10 <sup>-6</sup> (<7 x 10 <sup>-7</sup> )	
Maximum exhaust pressure	bar gauge (psig)	0.2 (2.9)			
Typical nitrogen consumption	slm	0	25	0	25
Cooling water consumption	lh <sup>-1</sup>	120			
Supply voltage	V	200/208/400 3 phase (+/- 10%)			
Supply frequency	Hz	50/60			
Power at ultimate	kW	1.4	1.6	1.4	1.6
Maximum power	kW	3.0			
Weight	kg (lb)	45 (98)	47 (103)	46 (102)	48 (106)
Inlet/outlet connection		ISO63/NW25		ISO160/NW25	
Water connection		3/8" Quick			
Noise	dB(A)	<56			
Vibration at inlet flange	mms <sup>-1</sup> (rms)	<1.3			

## Dimensions

EPX180

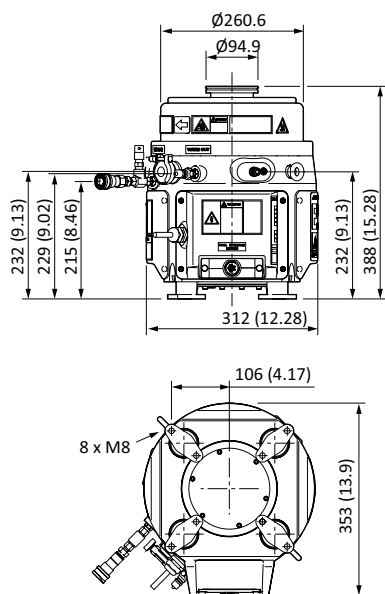

EPX500

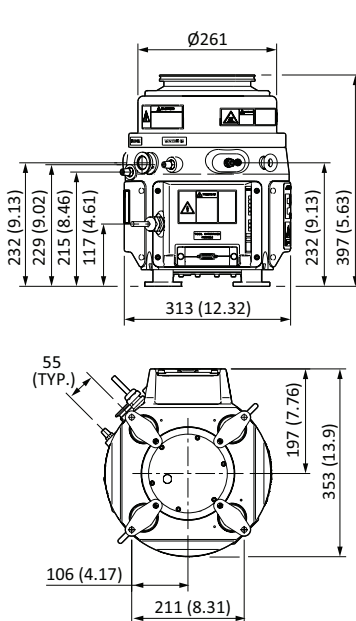

## Ordering information

Product description	Order number
EPX180LE 208V No TIM 3/8 water connectors	A41943012
EPX180LE 400V No TIM 3/8 water connectors	A41943014
EPX180LE 208V MCM TIM 3/8 water connectors	A41943712
EPX180LE 400V MCM TIM 3/8 water connectors	A41943714
EPX180NE 208V No TIM 3/8 water connectors	A41944012
EPX180NE 400V No TIM 3/8 water connectors	A41944014
EPX180NE 208V MCM TIM 3/8 water connectors	A41944712
EPX180NE 400V MCM TIM 3/8 water connectors	A41944714
EPX500LE 208V No TIM 3/8 water connectors	A41953012
EPX500LE 400V No TIM 3/8 water connectors	A41953014
EPX500LE 208V MCM TIM 3/8 water connectors	A41953712
EPX500LE 400V MCM TIM 3/8 water connectors	A41953714
EPX500NE 208V No TIM 3/8 water connectors	A41954012
EPX500NE 400V No TIM 3/8 water connectors	A41954014
EPX500NE 208V MCM TIM 3/8 water connectors	A41954712
EPX500NE 400V MCM TIM 3/8 water connectors	A41954714
Dry pump profibus module	D39752000

## Performance

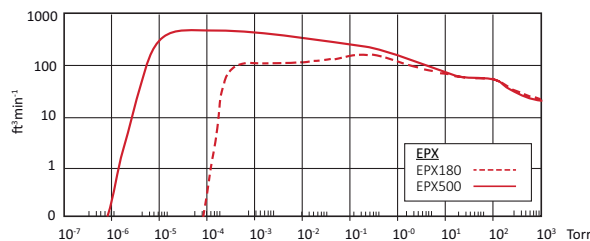
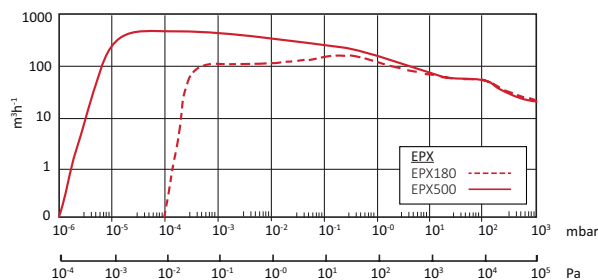

# GAMMA UHV PUMPS AND ACCESSORIES



Capture pumping technologies create high vacuum (HV) and ultra-high vacuum (UHV) environments for a variety of applications, ranging from portable mass spectrometers to large scale particle accelerators. They can create the highest possible vacuum at an economical cost.

Edwards offers a range of Ion Pumps, Titanium Sublimation Pumps, Non-Evaporable Getter Pumps and accessories exclusively through Gamma Vacuum.



## PRODUCT FEATURES

### MECHANICAL VIBRATION ELIMINATED

Capture pumps have no moving parts. Vibration from moving parts and electrical noise is eliminated.

### HIGH RADIATION TOLERANCE

Capture pumps are built with radiation tolerant materials in excess of  $10^8$  Gray. Connectors and cables are also built with radiation tolerant materials for years of continuous operation.

### HIGH TEMPERATURE TOLERANCE

Without any special consideration, capture pumps can be baked to 250 °C. Removing the magnets allows for hotter bakes up to 450 °C. Long hot bakes are critical to every UHV system.

### REGULAR MAINTENANCE ELIMINATED

Capture pumps require virtually no maintenance and avoid costly vacuum events because they are sealed from atmosphere, saving time, money and resources.

### LOW INITIAL AND OPERATIONAL COSTS

Initial cost is typically less than comparable specifications of other types of vacuum pumps. They use minimal or no power for years of low cost operation.

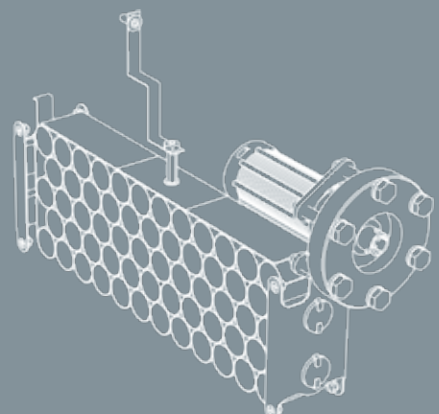

## Technical data: Smaller Pumps

	Units	Mini	3S	5S	10S	25S	45S	75S	
<b>Pumping speed</b>	l/s	0.2	2 - 3	4 - 5	8 - 10	15 - 20	30 - 40	40 - 75	
<b>Port option</b>									
Copper tube			CU						
DN16 (1.33") <sup>(1)</sup>		1V	1V, 1H or 1D						
DN40 (2.75") <sup>(2)</sup>				2V	2H	2V, 2H or 2D		2V or 2D	
DN63 (4.5") <sup>(3)</sup>							4V or 4D		
DN100 (6") <sup>(4)</sup>								6S or 62	
<b>Element choice</b>									
TiTan CV (Diode)			•	•	•	•	•	•	
TiTan DI (Noble Diode)		•	•	•	•	•	•	•	
TiTan CVX (Diode XHV)						•	•	•	
TiTan DIX (Noble Diode XHV)						•	•	•	
TiTan TR (Triode)						•	•	•	
<b>Feedthrough choice</b>									
MN Mini		•							
5K 5kV SHV			•	•					
SC 10kV SAFECONN				•	•	•	•	•	
OP Perkin Elmer						•	•	•	
OV Old Varian			•		•	•	•	•	
VR Varian StarCell®						•	•	•	
FI Fisher Interlock					•	•	•	•	
<b>Other data</b>									
Internal heater option					•	•	•	•	
Internal TSP/NEG option <sup>(5)</sup>						•	•	•	
Weight	kg (lbs)	0.35 (0.8)	0.45 (1.0)	2.3 (5)	6 (13)	9 (20)	16 (34)	22 (48)	
Shipping weight	kg (lbs)	3.5 (7.7)	0.9 (2.0)	2.8 (6)	8 (17)	11 (24)	18 (39)	25 (55)	
Ultimate pressure	mbar	<1 x 10 <sup>-11</sup>							
Starting pressure	mbar	<1 x 10 <sup>-3</sup>							
Lifetime (hrs at 1 x 10 <sup>-6</sup> mbar)	hours	Diode/Noble Diode 50,000; Triode 80,000							
Operating bake temperature	°C	100	95	200	250				
Maximum bake temperature <sup>(6)</sup>	°C	100					450		
Dimensions (L x W x D)	mm	38 x 38 x 51	138 x 41 x 50	106 x 85 x 81	200 x 153 x 79	202 x 125 x 130	209 x 251 x 130	277 x 242 x 130	

1 - 1V = 1" perpendicular to feedthrough; 1H = 1" inline with feedthrough; 1D = 1" double ports (perpendicular and inline)

2 - 2V = 2" top port; 2H = 2" side port; 2D = 2" double ports (top and side)

3 - 4V = 4" top port; 4D = 4" top port and 2" side port

4 - 6S = single 6" port; 62 = 6" top port and 2" side port

5 - Extra side or bottom port required

6 - Magnets removed

## Ordering information

Ion pumps and integrated TSP/NEG:

Ion pump	Element	Flange	Feedthrough	Heater	Integrated TSP/NEG
Mini 0.2l/s	CV Conventional diode	1V Perpendicular DN16	MN Mini	N None	N None
3S 3l/s	DI Noble diode	1H Inline DN16	5K 5kV SHV	1 110V	TSP TSP single filament
5S 5l/s	CX Diode XHV	1D Double DN16	SC 10kV SAFECONN	2 208-240V	N0 50l/s NEG (25/45/75)
10S 10l/s	DX Noble diode XHV	2V Vertical DN40	OP Perkin Elmer		N1 100l/s NEG (25/45/75)
25S 20l/s	TR Triode	2H Horizontal DN40	OV Old Varian		N2 200l/s NEG (45/75)
45S 40l/s		2D Double DN40	VR Varian StarCell®		N3 300l/s NEG (75)
75S 75l/s		4V Vertical DN63	FI Fisher Interlock		
		4D DN63/DN40			
		6S Single DN100			
		62 DN100/DN40			

## Technical data: Larger Pumps

	Units	100L	200L	300L	400L	400LX	600L	600LX	800LX	1200LX
<b>Pumping speed</b>	l/s	80 - 100	160 - 200	240 - 300	320 - 400	320 - 400	480 - 600	480 - 600	640 - 800	960 - 1200
<b>Port option</b>										
DN100 (6") <sup>(1)</sup>		6S or 6D								
DN160 (8") <sup>(2)</sup>			8S or 8D			8S, 8D or 8P	8S or 8D	8S, 8D or 8P	8S or 8D	
DN200 (10") <sup>(3)</sup>							10S or 10D	10S, 10D or 10P	10S or 10D	
<b>Element choice</b>										
TiTan CV (Diode)		•	•	•	•	•	•	•	•	•
TiTan DI (Noble Diode)		•	•	•	•	•	•	•	•	•
TiTan CVX (Diode XHV)		•	•	•	•	•	•	•	•	•
TiTan DIX (Noble Diode XHV)		•	•	•	•	•	•	•	•	•
TiTan TR (Triode)		•	•	•	•	•	•	•	•	•
<b>Feedthrough choice</b>										
SC 10kV SAFECONN		•	•	•	•	•	•	•	•	•
OP Perkin Elmer		•	•	•	•	•	•	•	•	•
OV Old Varian		•	•	•	•	•	•	•	•	•
*VR Varian StarCell®		•	•	•	•	•	•	•	•	•
FI Fisher Interlock		•	•	•	•	•	•	•	•	•
<b>Other data</b>										
Internal heater option		•	•	•	•	•	•	•	•	•
Internal TSP/NEG option <sup>(4)</sup>		•	•	•	•	•	•	•	•	•
Weight	kg (lbs)	29 (65)	50 (112)	66 (145)	67 (148)	95 (210)	103 (226)	122 (270)	127 (280)	206 (452)
Shipping weight	kg (lbs)	47 (105)	69 (152)	89 (195)	85 (188)	113 (250)	127 (280)	141 (310)	145 (320)	254 (560)
Ultimate pressure	mbar	<1 x 10 <sup>-11</sup>								
Starting pressure	mbar	<1 x 10 <sup>-3</sup>								
Lifetime (hrs at 1 x 10 <sup>-6</sup> mbar)	hours	Diode/Noble Diode 50,000; Triode 80,000								
Operating bake temperature	°C	250								
Maximum bake temperature <sup>(5)</sup>	°C	450								
Dimensions (L x W x D)	mm	326 x 128 x 252	325 x 413 x 233	325 x 413 x 337	325 x 413 x 413	537 x 413 x 233	325 x 513 x 513	537 x 413 x 336	537 x 413 x 413	650 x 513 x 513

1 - 6S = single 6" port; 6D = double 6" ports (top and bottom)

2 - 8S = single 8" port; 8D = double 8" ports (top and bottom); 8P = double 8" ports (top and side)

3 - 10S = single 10" port; 10D = double 10" ports (top and bottom); 10P = double 10" ports (top and side)

4 - Extra side or bottom port required

5 - Magnets removed

## Ordering information

Ion pumps and integrated TSP/NEG:

Ion pump	Element	Flange	Feedthrough	Heater	Integrated TSP/NEG
100L 100l/s	CV Conventional diode	6S Single DN100	SC 10kV SAFECONN	N None	N None
200L 200l/s	DI Noble diode	6D 2x DN100 (top/bottom)	OP Perkin Elmer	1 110V	TC TSP & Cryoshroud (not 100L)
300L 300l/s	CX Diode XHV	8S Single DN160	OV Old Varian	2 208-240V	TA TSP & Ambient Shield
400L 400l/s	DX Noble diode XHV	8D 2x DN160 (top/bottom)	VR Varian StarCell®		NG 400l/s NEG
400LX 400l/s	TR Triode	8P 2x DN160 (top/side)	FI Fisher Interlock		
600L 600l/s		10S Single DN200			
600LX 600l/s		10D 2x DN200 (top/bottom)			
800LX 800l/s		10P 2x DN200 (top/side)			
1200LX 1200l/s					

\*STARCELL® is a registered trademark of Agilent Technologies

**Titanium Sublimation Pumps (TSPs) are often used in combination with ion pumps or independently to remove reactive gases from the vacuum environment. Combined with an ion pump, the TSP allows for low ultimate pressures in a shorter amount of time. All TSP components are bakeable to 400 °C.**

TSPs operate by heating a titanium filament and subliming (converting from solid to gas phase) titanium molecules onto a surface. Sublimed titanium molecules are then available to chemically react with reactive gases, like oxygen and nitrogen, and disassociate and diffuse hydrogen. TSPs can operate from  $10^{-5}$  to  $10^{-12}$  mbar and have pumping speeds in excess of 10,000  $l s^{-1}$  for hydrogen.



## PRODUCT FEATURES

### TSP FILAMENT CARTRIDGE

The filament cartridge is mounted on a 2- 3/4" CFF (DN40). The feedthrough supports three titanium-molybdenum filaments and a return path for ground isolation. Each filament contains 1.5 grams of usable titanium and averages 20 hours of operation.



### LIQUID CRYOSHROUD

The liquid cryoshroud consists of a double walled, type 304L stainless steel cylinder with two liquid nitrogen feedthroughs (.375 in. diameter) with flare type fittings. It provides 1578  $cm^2$  (245  $in^2$ ) of liquid nitrogen cooled surface area that provides pumping speeds up to 12,000  $l s^{-1}$  for hydrogen (see table). The shroud is mounted on an 8 in. CFF (DN160).



### AMBIENT SPUTTER SHIELD

The ambient sputter shield economically maximizes surface area when cooling is not practical or possible. It provides 827  $cm^2$  (128  $in^2$ ) of ambient temperature surface area that provides pumping speeds up to 2200  $l s^{-1}$  for hydrogen (see table). The shield is mounted on an 8 in. CFF (DN160) or a 6 in. CFF (DN100).

## Technical data

	Area	Temperature	H <sub>2</sub>		CO		H <sub>2</sub> O	
			Rate	Speed	Rate	Speed	Rate	Speed
Typical TSP pumping speeds	cm <sup>2</sup> /inch <sup>2</sup>	°C	l s <sup>-1</sup> / cm <sup>2</sup>	l s <sup>-1</sup>	l s <sup>-1</sup> / cm <sup>2</sup>	l s <sup>-1</sup>	l s <sup>-1</sup> / cm <sup>2</sup>	l s <sup>-1</sup>
Liquid cryoshroud (8")	709/110	20	2.6	1843	8.2	5814	7.3	5176
	1578/245 <sup>(1)</sup>	-195	17	12053	11	7799	14.6	23039
Ambient sputter shield (8")	827/128	20	2.6	2150	8.2	6780	7.3	6037
Ambient sputter shield (6")	621/96	20	2.6	1614	8.2	5092	7.3	4533

(1) applies to H<sub>2</sub>O speed only

## Ordering information

Product description	Order number	Product description	Order number
TSP cartridge 3 filaments 2-3/4" CFF	G360819	1.5 metre cable with MS connectors	MSHC1MS
TSP ambient sputter shield 6" CFF	G360190	3 metre cable with MS connectors	MSHC3MS
TSP ambient sputter shield 8" CFF	G360044	6 metre cable with MS connectors	MSHC6MS
TSP liquid cryoshroud 8" CFF	G360051	10 metre cable with MS connectors	MSHC10MS

# NON-EVAPORABLE GETTER PUMPS (NEG)

NEGs are reactive metals that have been pressed onto solid substrates or sintered into discs. The amount of material used controls the speed and capacity of the NEG pump, but typically ranges from 50 to 3,500  $\text{ls}^{-1}$  of hydrogen. As NEGs become saturated with gases, they can be reactivated without venting to atmosphere. Their prime advantage is their ability to pump for extended periods without the need for power.

NEGs are ideal for pump down, stay down applications and can be used to boost the performance of an ion pump or as a standalone pump. They are ideal for UHV applications due to their compact size and high  $\text{H}_2$  pumping speed. They are not suitable for applications that cycle up to atmospheric pressure regularly as this will saturate the surface and they can only be reactivated a finite number of times.



N50



N100



N200



N300



N400

## Technical data

	Units	N50	N100	N200	N300	N400
Flange		DN40 (2.75") CFF				
Total mass	kg (lbs)	0.48 (1.05)	0.54 (1.19)	0.75 (1.65)	0.8 (1.79)	0.85 (1.88)
Alloy composition		Zr (70%), V (24.6%), Fe (5.4%)				
Getter mass	g	31.5	58	108	144	180
Getter surface	$\text{cm}^2$	187	348	642	856	1070
$\text{H}_2$ pumping speed	$\text{ls}^{-1}$	55	106	208	312	412
CO pumping speed	$\text{ls}^{-1}$	27	51	94	125	156
$\text{H}_2$ sorption capacity	Torr l	630	1170	2160	2880	3600
CO (25 °C) sorption capacity	Torr l	0.1	0.2	0.4	0.6	0.8
CO total sorption capacity	Torr l	284	526	972	1296	1620
Insertion length	mm	46	61	89	110	130
Diameter	mm	34				

## Ordering information

Product description	Order number	Product description	Order number
50 $\text{ls}^{-1}$ NEG cartridge pump 2-3/4" CFF	GN50	400 $\text{ls}^{-1}$ NEG cartridge pump 2-3/4" CFF	GN400
100 $\text{ls}^{-1}$ NEG cartridge pump 2-3/4" CFF	GN100	1 metre cable with XLR connectors	XLRS1N100
200 $\text{ls}^{-1}$ NEG cartridge pump 2-3/4" CFF	GN200	3 metre cable with XLR connectors	XLRS3N100
300 $\text{ls}^{-1}$ NEG cartridge pump 2-3/4" CFF	GN300	6 metre cable with XLR connectors	XLRS6N100



The DIGITEL™ family of ion pump controllers offers the right balance of performance, power and protection.

### Digitel™ SPCe small pump controller

The SPCe is a versatile way to fully operate a single ion pump. An LCD pressure/current/voltage display along with standard serial communications makes the SPCe able to accommodate the needs of basic and advanced users.



### Digitel™ QPC quad pump controller

The new QPC controller offers adjustable output voltage, nano ampere resolution plus up to four independent power supplies, allowing for high current control of up to four ion pumps independently. It has an easy-to-read colour touchscreen LCD display that simultaneously displays pressure, current, and voltage and includes serial and ethernet communications as standard.



### Digitel™ TSPq and NEGq controller

The TSPq/NEGq controller has an easy-to-read touchscreen LCD display that displays all manual or programmed firing parameters. Manual operation is as simple as pressing one button. Programming is just as easy by viewing all programming options on one screen. The TSPq/NEGq controller can operate up to 8 TSP filaments or 2 NEG pumps.



## Technical data

	Units	SPCe	QPC	TSPq	NEGq
<b>Input power</b>					
Voltage		90-240 V a.c. or 24 V d.c.		90-130 or 200-240 V	
Frequency	Hz	48-62			
<b>Output power</b>					
Independent outputs		1	1 to 4	1	1
Open circuit voltage		3000-7000 V d.c. (+/- configurable)		17 V a.c.	35 V a.c.
Current (maximum)	mA	50	125	55000	8000
Watts (maximum)	W	50	125	800	220
Resolution		1 nA	1 nA	0.1 A	-
High voltage connections		1 10 kV SHV or Fischer	1-4 10 kV SHV or Fischer	1-2 MS style, configurable	1-2 XLR
Display type		LCD	1/4 VGA colour touchscreen LCD	1/4 VGA touchscreen LCD	1/4 VGA touchscreen LCD
Readouts		Pressure, current, voltage and programmable options		Current, on-time and programmable options	
<b>Analog outputs</b>					
Voltage		Linear, configurable			
Current/pressure		Linear or logarithmic, configurable			
Setpoints		One relay, one TTL	Four relay, four TTL		
Communications		Local/Remote/Full Ethernet Serial: 232, 422, 485			
Weight	kg (lbs)	1.5 (3.3)	9.5 (21)	16.8 (37)	
Size		2U high, 1/4 rack wide		3U high, 1/2 rack wide	
		313 mm (12.3") deep		438 mm (17.2") deep	
Additional features		SAFECONN	SAFECONN	Manual, programmed or remote control	
		AUTOSTART/AUTORUN	AUTOSTART/AUTORUN	TSP enable	NEG enable
		High voltage enable Fowler-Nordheim calibration	High voltage enable		
		High-pot capability			

# ION PUMP CABLES

## SAFECONN™ High voltage interlock

The integrated SAFECONN™ high voltage interlock system was introduced by Gamma Vacuum to create a safe environment when working with the high voltage cables of an ion pump.

Materials carry up to 10kV of DC current at temperatures up to 250° C. Radiation tolerance is balanced with material flexibility to provide a 90° turning radius while maintaining exposures up to  $2 \times 10^5$  Gray.

The silicone cable carries high voltage and an isolated 5-volt signal for the safety circuit. When properly connected, the 5-volt circuit is satisfied and only then can the DIGITEL™ controllers enable high voltage by the end user or through remote commands.

Once high voltage is enabled, the controller automatically disables high voltage when the cable is disconnected from the ion pump or controller.

The system is electrically isolated to eliminate noise potential that could interfere with other electrical equipment on the same vacuum system.

The SAFECONN safety connection guarantees ground, high voltage, and then safety interlock connectivity when connecting to prevent accidental arcing.

The SAFECONN system guarantees the safety of the operator and equipment from the hazards of working with high voltage by eliminating electrical shocks and false positive vacuum

## Standard SAFECONN Connector Options



### Controller Connector Options

Compatible with Gamma Vacuum or Agilent/Varian Interlock System

### Pump End Options

Compatible with current or legacy Gamma Vacuum or Agilent/Varian Feedthroughs (non- SAFECONN connectors available)

## Technical data

Material (reference)	Radiation (Gray, tolerance)	Temperature (°C, max)
Copper (1, 3, 4)	>10 <sup>8</sup>	250
Brass/nickel (8)	>10 <sup>8</sup>	327
Beryllium/copper/gold (8)	>10 <sup>8</sup>	643
Spring steel/nickel (8)	>10 <sup>8</sup>	1427
PEEK (8)	$5 \times 10^7$	325
Fiberglass braid (6)	$2 \times 10^7$	250
Silicone rubber (2, 5, 7, 8)	$2 \times 10^5$	250

## Specification

Description	Unit	Value
Bend Radius	mm (in)	12.7 (0.5)
Diameter, nominal	mm (in)	8.0 (0.3)
Minimum removal clearance	mm (in)	127 (5.0)

## Ordering information

Controllers:

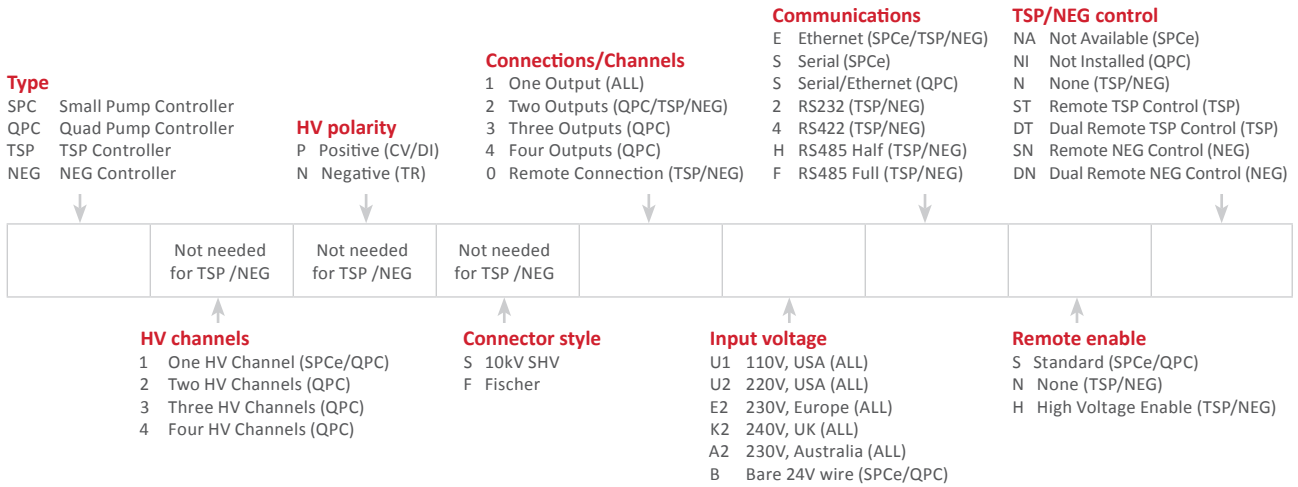

Ion pump cables:

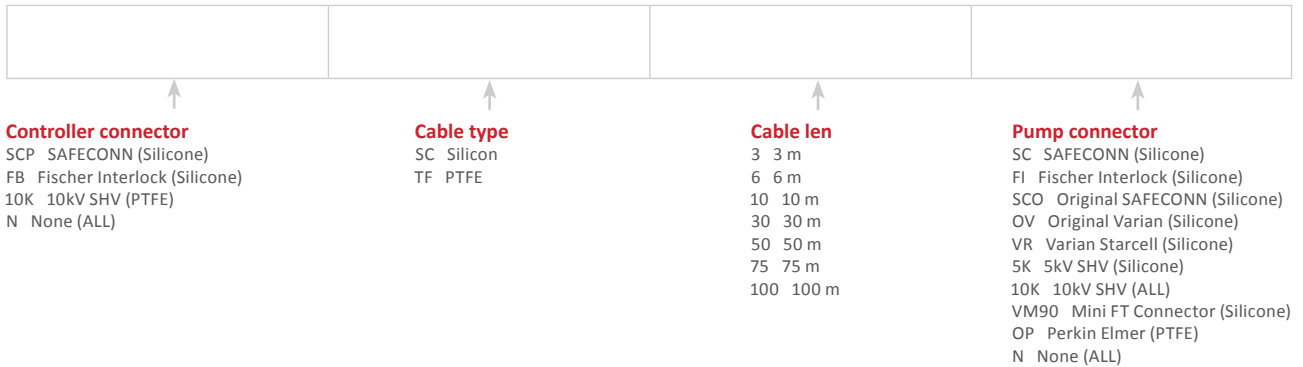



## APG100- Active Pirani Gauge

10 <sup>-10</sup>	10 <sup>-9</sup>	10 <sup>-8</sup>	10 <sup>-7</sup>	10 <sup>-6</sup>	10 <sup>-5</sup>	10 <sup>-4</sup>	10 <sup>-3</sup>	10 <sup>-2</sup>	10 <sup>-1</sup>	1	10	10 <sup>2</sup>	10 <sup>3</sup>
Ultra High Vacuum		High Vacuum				Medium Vacuum			Low Vacuum				

APG100 series Active Pirani vacuum gauges are available in 2 models. The APG100-XM is the standard model and measures to 10<sup>-3</sup> mbar, the APG100-XLC is a corrosion resistant version with measurement to 10<sup>-4</sup> mbar. Both gauges feature compact size for easy installation, a linear output and a replaceable sensor tube. These gauges are compatible with all Edwards TIC instrument controllers and other Active gauge controllers and displays.



Technical data	
Pressure range	APG100-XM = 10 <sup>3</sup> to 10 <sup>-3</sup> mbar APG100-XLC = 10 <sup>3</sup> to 10 <sup>-4</sup> mbar
Accuracy	APG100-XM = <100 mbar APG100-XLC = <10 mbar typically +/- 15%
Max overpressure	10 bar absolute (145 psi)
Temperature range	
Operating	+5 to +60 °C
Storage	-30 to +70 °C
Maximum bakeout temperature with electronics removed	150 °C

Active Pirani Gauges	Order number
APG100-XM atmosphere to 10 <sup>-3</sup> mbar NW16 flange	D02601000
APG100-XM atmosphere to 10 <sup>-3</sup> mbar NW25 flange	D02602000
APG100-XM DN16CF	NRD710000
APG100-XLC atmosphere to 10 <sup>-4</sup> mbar corrosion resistant NW16 flange	D02603000
APG100-XLC atmosphere to 10 <sup>-4</sup> mbar corrosion resistant NW25 flange	D02604000
APG100-XLC DN16CF	NRD712000

## APGX H- Active Linear Convection Gauge

10 <sup>-10</sup>	10 <sup>-9</sup>	10 <sup>-8</sup>	10 <sup>-7</sup>	10 <sup>-6</sup>	10 <sup>-5</sup>	10 <sup>-4</sup>	10 <sup>-3</sup>	10 <sup>-2</sup>	10 <sup>-1</sup>	1	10	10 <sup>2</sup>	10 <sup>3</sup>
Ultra High Vacuum		High Vacuum				Medium Vacuum			Low Vacuum				

The Active Linear Convection Vacuum Gauge has a wide measuring range from 1333 to 3 x 10<sup>-4</sup> mbar. The use of convection technology ensures accuracy and sensitivity are maintained to the top of the pressure range compared to conventional Pirani gauges, which lose accuracy above 100 mbar. The gauge is compact and may be mounted in any orientation, simplifying installation where space is limited.



Technical data	
Pressure range	1333 to 3 x 10 <sup>-4</sup> mbar
Accuracy	Typically +/- 15%
Max overpressure	10 bar absolute (145 psi)
Temperature range	
Operating	+5 to +60 °C
Storage	-30 to +70 °C
Maximum bakeout temperature with electronics removed	70 °C

APGX H - Active Linear Convection Gauges	Order number
APGX-H NW16 aluminium	D02391000
APGX-H NW16 stainless steel	D02395000
APG100-XM DN16CF	NRD710000
APG100-XLC DN16CF	NRD712000
APGX-H NW25 stainless steel	D02392000
APGX-H 1/8" NPT stainless steel	D02396000

## AIM- Active Inverted Magnetron Gauge

10 <sup>-10</sup>	10 <sup>-9</sup>	10 <sup>-8</sup>	10 <sup>-7</sup>	10 <sup>-6</sup>	10 <sup>-5</sup>	10 <sup>-4</sup>	10 <sup>-3</sup>	10 <sup>-2</sup>	10 <sup>-1</sup>	1	10	10 <sup>2</sup>	10 <sup>3</sup>
Ultra High Vacuum		High Vacuum				Medium Vacuum		Low Vacuum					

Edwards Active Inverted Magnetron (AIM) Gauges provide accurate measurement over the vacuum range of  $1 \times 10^{-2}$  to  $1 \times 10^{-9}$  mbar. These gauges have proved to be rugged and reliable in a wide range of applications, ranging from scientific instruments to industrial processes.

The AIM-X Gauge is an inverted magnetron gauge head and gauge controller combined into a single compact unit, and features a linear output for easy integration with a computer or PLC.

The XL variants have a very low external magnetic field, these are ideally suitable for use with sensitive analytical instruments or in applications where the gauge needs to be mounted in close proximity to a turbomolecular pump.



Technical data	
Pressure range	10 <sup>-2</sup> to 10 <sup>-9</sup> mbar
Accuracy	Typically +/- 30%
Max overpressure	10 bar absolute (145 psi)
Temperature range	
Operating	+5 to +60 °C
Storage	0 to +70 °C
Maximum bakeout temperature with electronics removed	NW25 70 °C DN40CF 300 °C

Active Inverted Magnetron Gauges	Order number
AIM-X-NW25	D14642000
AIM-XL-NW25	D14645000
AIM-X-DN40CF	D14662000
AIM-XL-DN40CF	D14665000

## AIGX- Active Ion Gauge

10 <sup>-10</sup>	10 <sup>-9</sup>	10 <sup>-8</sup>	10 <sup>-7</sup>	10 <sup>-6</sup>	10 <sup>-5</sup>	10 <sup>-4</sup>	10 <sup>-3</sup>	10 <sup>-2</sup>	10 <sup>-1</sup>	1	10	10 <sup>2</sup>	10 <sup>3</sup>
Ultra High Vacuum		High Vacuum				Medium Vacuum		Low Vacuum					

The Active Ion Gauge (AIGX) is a compact active ion gauge with dual yttria coated iridium filaments, a wide measuring range from  $6.6 \times 10^{-2}$  to  $6.6 \times 10^{-10}$  mbar and a 1 Volt/decade linear output. The AIGX incorporates all benefits of the industry standard active gauging concept, with integral electronics and replaceable tube. The gauge has a degas facility and includes features to protect and extend the life of the filaments. The AIGX benefits from extremely low emissions of charged particles, which makes it an excellent choice for processes where background noise is undesirable.



Technical data	
Pressure range	$6.6 \times 10^{-2}$ to $6.6 \times 10^{-10}$ mbar
Accuracy	Typically +/- 15%
Max overpressure	10 bar absolute (145 psi)
Temperature range	
Operating	0 to +40 °C
Storage	-30 to +70 °C
Maximum bakeout temperature with electronics removed	200 °C

AIGX - Active Ion Gauge	Order number
AIGX-S NW25	D04850000
AIGX-S DN16CF	D04851000
AIGX-S DN40CF	D04852000

## WRG- Wide Range Gauge

10 <sup>-10</sup>	10 <sup>-9</sup>	10 <sup>-8</sup>	10 <sup>-7</sup>	10 <sup>-6</sup>	10 <sup>-5</sup>	10 <sup>-4</sup>	10 <sup>-3</sup>	10 <sup>-2</sup>	10 <sup>-1</sup>	1	10	10 <sup>2</sup>	10 <sup>3</sup>
Ultra High Vacuum		High Vacuum				Medium Vacuum			Low Vacuum				

The Wide Range Gauge (WRG) family offers the capability of single port pressure measurement in the range atmosphere to 10<sup>-9</sup> mbar, with a linear output. It's a compact solution, halving the space and connectivity hardware requirement, which can be all important in many applications. The WRG has many novel features, including a patented striker, push-button calibration and set point controls and comprehensive diagnostics. The WRG is a cost-effective vacuum management solution when used either with an Edwards controller or directly integrated into the vacuum system controls.



Technical data	
Pressure range	10 <sup>3</sup> to 10 <sup>-9</sup> mbar
Accuracy	Typically +/- 15% at <100 mbar +/- 30% at <10 <sup>-3</sup> mbar
Max overpressure	10 bar absolute (145 psi)
Temperature range	
Operating	+5 to +60 °C
Storage	0 to +70 °C
Maximum bakeout temperature with electronics removed	70 °C

Wide Range Gauges	Order number
WRG NW25 stainless steel	D14701000
WRG DN40CF stainless steel	D14703000
WRG-SL NW25 low stray magnetic field	D14711000

## Active gauge cables

Connection cable options	Order number
0.5 m	D40001005
1 m	D40001010
3 m	D40001030
5 m	D40001050
10 m	D40001100
15m	D40001150
25m	D40001250
50m	D40001500

Cables include FCC68/RJ45 compatible connections at both ends.

# ACTIVE GAUGE CONTROLLERS

## Active Digital Controller

The Active Digital Controller (ADC) is a compact single gauge controller and display. It features a bright LED display and simple push button controls. The ADC automatically recognises compatible Edwards gauges, loads the appropriate look-up table and displays the pressure in commonly used vacuum units.



- Plug and measure operation
- Bright LED display for clear visibility
- Choice of display units - mbar, Torr, Pascal
- Supports APG100, APGXH and WRG gauges

## Enhanced Active Digital Controller

The Enhanced Active Digital Controller (ADC) is a compact dual gauge controller and display. It features a bright LED display and simple push button controls for two compatible Edwards gauges. The Enhanced ADC automatically loads the appropriate look-up table and displays the pressure in commonly used vacuum units.



- Controls two active gauges of the same type
- 2 set-point relays
- Simple push button control
- RS232 interface and analog output
- Supports APG100, APGXH, WRG and AIM gauges

## TIC Controller

The TIC instrument controller offers comprehensive control and display of up to 6 compatible Edwards gauges. Intuitive user interface, 6 set points and full Windows Software for control and data logging functionality.



- Universal controller for up to 6 active gauges
- Compact design
- Clear, easy-to-use graphical user interface
- Serial communication Windows™ PC program including data logger, plus analogue outputs
- RS232 interface and analogue output
- Supports APG100, APGXH, WRG, AIM and AIGX gauges

Controller	Order number	Max no. of gauges	No. of setpoints	Windows software	Data logging
TIC controller (3 gauge)	D39700000	3	3	Yes	Yes
TIC controller (6 gauge)	D39701000	6	6	Yes	Yes
Active digital controller (ADC)	D39590000	1	0	No	No
Enhanced digital controller (eADC)	D39591500	2	2	No	No
UK power cable for TIC/ADC	D40013025				
EU power cable for TIC/ADC	D40013030				
US power cable for TIC/ADC	D40013120				



## PRG20K- Pirani Gauge Sensors

10 <sup>-12</sup>	10 <sup>-11</sup>	10 <sup>-10</sup>	10 <sup>-9</sup>	10 <sup>-8</sup>	10 <sup>-7</sup>	10 <sup>-6</sup>	10 <sup>-5</sup>	10 <sup>-4</sup>	10 <sup>-3</sup>	10 <sup>-2</sup>	10 <sup>-1</sup>	1	10	10 <sup>2</sup>	10 <sup>3</sup>
Ultra High Vacuum				High Vacuum				Medium Vacuum			Low Vacuum				

The Pirani Gauge Sensors are available in 3 models. The PRG20K-NW16 Al is an aluminium sensing cell with tungsten filament. The PRG20K-DN16CF SS is a stainless steel sensing cell with tungsten filament and is overpressure resistant. The PRG20KCR-NW16 SS is a stainless steel sensing cell with platinum filament and ceramics feed through, which is well suited for corrosive processes and water vapour atmospheres.



### Technical data

PRG20K	
Pressure range	10 <sup>3</sup> to 0.5x10 <sup>-4</sup> mbar
Accuracy	<10 <sup>-2</sup> mbar ±20% 10 <sup>-2</sup> to 10 <sup>2</sup> mbar ±15%
Max overpressure	3 bar (aluminium tube) 10 bar (stainless tube)
Temperature range	
Operating	0 to +40 °C
Storage	-20 to +70 °C
Maximum bakeout temperature	80 °C
Radiation tolerance	5x10 <sup>4</sup> Grays

### Ordering information

Product description	Order number	Product description	Order number
PRG20K - NW16 Al	D03000200	PRG cable 10m	D03000202
PRG20K - DN16CF SS	D03000210	PRG cable 20m	D03000203
PRG20KCR - NW16 SS	D03000220	PRG cable 30m	D03000204
PRG cable 5m	D03000201	PRG cable 50m	D03000205

## CPG35K - Penning Gauge Sensors

10 <sup>-12</sup>	10 <sup>-11</sup>	10 <sup>-10</sup>	10 <sup>-9</sup>	10 <sup>-8</sup>	10 <sup>-7</sup>	10 <sup>-6</sup>	10 <sup>-5</sup>	10 <sup>-4</sup>	10 <sup>-3</sup>	10 <sup>-2</sup>	10 <sup>-1</sup>	1	10	10 <sup>2</sup>	10 <sup>3</sup>
Ultra High Vacuum			High Vacuum				Medium Vacuum			Low Vacuum					

The Penning Gauge Sensors are available in 4 models. All 4 have a measurement range of 1 x 10<sup>-9</sup> to 10<sup>-2</sup> mbar (0.75 x 10<sup>-9</sup> to 10<sup>-2</sup> Torr) and are insensitive to air rushes and vibration. These passive sensors use cold cathode ionization technology according to Penning. The cathode plate is exchangeable, and demonstrates improved ignition through the use of titanium cathodes. The CPG35KB is bakeable to 200 °C.



### Technical data

CPG35K	
Pressure range	10 <sup>-2</sup> to 10 <sup>-9</sup> mbar
Accuracy	10 <sup>-4</sup> to 10 <sup>-8</sup> mbar ±30%
Max overpressure	10 bar
Temperature range	
Operating	+5 to +80 °C
Storage	-20 to +70 °C
Maximum bakeout temperature	Standard gauge 80 °C bakeable gauge 200 °C
Radiation tolerance	10 <sup>6</sup> Grays

### Ordering information

Product description	Order number	Product description	Order number
CPG35K - NW40	D03000100	CPG cable 5m	D03000101
CPG35K - DN40CF	D03000110	CPG cable 10m	D03000102
CPG35K - NW25	D03000130	CPG cable 20m	D03000103
CPG35KB - DN40CF	D03000140	CPG cable 30m	D03000104
		CPG cable 50m	D03000105

## IG40- Ion Gauge Sensors

10 <sup>-12</sup>	10 <sup>-11</sup>	10 <sup>-10</sup>	10 <sup>-9</sup>	10 <sup>-8</sup>	10 <sup>-7</sup>	10 <sup>-6</sup>	10 <sup>-5</sup>	10 <sup>-4</sup>	10 <sup>-3</sup>	10 <sup>-2</sup>	10 <sup>-1</sup>	1	10	10 <sup>2</sup>	10 <sup>3</sup>
Ultra High Vacuum				High Vacuum				Medium Vacuum			Low Vacuum				

Using hot cathode ionization technology, both the Bayard-Alpert and Extractor gauges have highly accurate individually calibrated sensing systems and exchangeable cathodes. The Bayard-Alpert sensing system has a measurement range from 10<sup>-2</sup> to 2 x 10<sup>-11</sup> mbar (1.5 x 10<sup>-11</sup> Torr) with its protection shield welded in place. The Extractor sensing system has a measurement range from 10<sup>-4</sup> to 2 x 10<sup>-12</sup> mbar (1.5 x 10<sup>-12</sup> Torr), alongside a significant reduction of X-ray and ion desorption effects.



### Technical data

	IG40 BA	IG40 EX
Pressure range	10 <sup>-2</sup> to 2x10 <sup>-11</sup> mbar	10 <sup>-2</sup> to 2x10 <sup>-12</sup> mbar
Accuracy	±2%, ±5x10 <sup>-13</sup> mbar	±2%, ±3x10 <sup>-13</sup> mbar
Max overpressure	2 bar	2 bar
Temperature range		
Operating	+20 to +80 °C	+20 to +80 °C
Storage	+20 to +50 °C	+20 to +50 °C
Maximum bakeout temperature	With cable 250 °C Without cable 400 °C	With cable 250 °C Without cable 400 °C
Radiation tolerance	10 <sup>6</sup> Grays	10 <sup>6</sup> Grays

### Ordering information

Gauge type	Product description	Order number
Ion gauge	IG40 BA DN40CF	D03000300
Ion gauge	IG40 EX DN40CF	D03000310

Accessories	Product description	Order number
Ion gauge	IG40 BA / EX cable 5 m bakeable	D03000301
Ion gauge	IG40 BA / EX cable 10m bakeable	D03000302
Ion gauge	IG40 BA / EX cable 50m bakeable	D03000305

## PGC201 Pirani and Penning Controller/PGC202 Pirani and Ion Controller

Edwards PGC201 controller covers the pressure range between  $10^{-9}$  and 1000 mbar by combining two measurement principles from the PRG and CPG gauges. The PGC202 combines PRG gauges and IG40 BA or IG40 EX gauges for measurements of vacuum pressures in the range between  $10^{-12}$  and 1000 mbar. Both these controllers provide monitoring and control functions for the connected gauges.



- Compact 3 channel operating unit for a pressure range for passive sensors of  $-10^{-9}$  to 1000 mbar  
PGC201  $-10^{-12}$  to 1000 mbar PGC202
- Automatic switchover from Pirani operation to Penning cold cathode operation (PGC201)
- UHV sensors either Bayard-Alpert measurement system IG40 BA or Extractor measurement system IG40 EX (PGC202)
- Measurement cable lengths up to 50 meters
- Easy to operate

### Ordering information

Controllers	Product description	Order number
Pirani/Penning	PGC201	D03000400
Pirani/Ion	PGC202	D03000410

### Connectable sensors

Pirani	Penning Gauge (only PGC201)	Ion Gauge (only PGC202)
PRG20K - NW16 AI	CPG35K - NW25	IG40 BA DN40CF
PRG20K - DN16CF SS	CPG35K - NW40	IG40 EX DN40CF
PRG20KCR - NW16 SS	CPG35K - DN40CF	
	CPG35KB - DN40CF	

# ELD500 PRECISION LEAK DETECTOR



The ELD500 precision leak detector is designed for fast, accurate leak detection in a wide range of applications, fully mobile and with an easy to control interface. Featuring with low energy consumption, extended warranty and even longer life ion source, Edwards ELD500 leak detector ensures exceptional low cost of ownership with no compromise on performance.

Available in three variants: FLEX, WET and DRY, Edwards ELD500 leak detector is versatile. All models feature a rugged turbomolecular pump optimised for the rigours of portable leak detection, ideal across all applications.



## PRODUCT FEATURES

### FLEXIBLE REMOTE CONTROL OPTIONS

Colour touch screen control with local graphical display and audible leak detection. Wireless models allow simultaneous control of up to 10 leak detectors.

### MOBILE SOLUTION

Low weight and integrated carry handles which allow it to be bench top or trolley mounted.

### HIGH SENSITIVITY

Measurement of leaks for Helium of  $<5 \times 10^{-12}$  mbar  $l s^{-1}$  in vacuum mode and  $<7 \times 10^{-9}$  mbar  $l s^{-1}$  in sniffer mode.

### CUSTOMISABLE FOR ANY APPLICATION

- WET version with an integrated oil sealed rotary vane pump
- DRY version with an integrated helium optimised diaphragm pump
- FLEX version without a primary pump.

### PARTIAL FLOW KIT

Allows effective pump down of large of contaminate flows compatible with WET and FLEX variants.

### ACCURATE PIN-POINTING OF LEAKS

Standard sniffer line enables operation up to 4m from the ELD500. Longer sniffer lines of up to 50m can be used with the sniffer extender interface.

### LONG TERM STABILITY

Ensured by class leading  $180^\circ$  mass spectrometer.

## Technical data

ELD500 Leak Detector	Units	WET	DRY	FLEX
<b>Lowest detectable helium leak rate</b>				
Vacuum operation	mbar ls <sup>-1</sup>	≤ 5 x 10 <sup>-12</sup>	≤ 3 x 10 <sup>-11</sup>	≤ 5 x 10 <sup>-12</sup>
Sniffer operation	mbar ls <sup>-1</sup>	≤ 7x10 <sup>-9</sup>	≤ 7x10 <sup>-9</sup>	≤ 7x10 <sup>-9</sup>
<b>Maximum measurable helium leak rate</b>				
Vacuum operation	mbar ls <sup>-1</sup>	> 0.1	> 0.1	> 0.1
Measurement ranges	decades	12	12	12
Maximum permissible inlet pressure	mbar	15	15	15
Pumping speed during pumpdown, 50 Hz/60 Hz	m <sup>3</sup> h <sup>-1</sup>	2.5/3	1.6/1.8	N/A
Helium pumping speed in the fine mode	ls <sup>-1</sup>	3.1	3.1	3.1
Time constant for leak rate signal	s	< 1	< 1	< 1
Time until ready for operation	min	≤ 2	≤ 2	≤ 2
Power consumption	VA	420	350	200
Inlet flange		NW25	NW25	NW25
Dimensions (WxHxD)	mm	495x456x314	495x456x314	495x456x314
Weight	kg	40	35.5	30

## Ordering information

Product description	Order number
ELD500 WET, 200-240V,50/60Hz	D13510903
ELD500 WET, 100-120V, 50/60Hz	D13510904
ELD500 WET, 100-120V, 60Hz	D13510906
ELD500 DRY, 200-240V,50/60Hz	D13520903
ELD500 DRY, 100-120V, 50/60Hz	D13520904
ELD500 DRY, 100-120V, 60Hz	D13520906
ELD500 FLEX, 100-240V,50/60Hz	D13530000
ELD500 RC - wired - remote control	D13550100
ELD500 RC - wireless - remote control	D13550110
ELD500 RC - wired - 8m extension cable	14022
ELD500 RC - wireless - extra transmitter	D13550130
ELD500 SL - standard sniffer line 4m	D13550300
ELD500 SL - extended SL Interface	D13550200
ELD500 SL - extended sniffer line 5m	14008
ELD500 SL - extended sniffer line 20m	14009
ELD500 SL - extended sniffer line 50m	12183
ELD500 partial flow adaptor	D13550400
ELD500 transport case	D13550500
ELD500 mobile trolley	D13550630
ELD500 SG - helium spray gun	16555
CL-internal calibrated leak	D13550910
CL-cal leak bspk. 0.5 - 1E-7. screw skt	D13550930
CL-calibrated leak HE 4 to 6	D13550950

## Extended warranty

Product description	Order number
Extended warranty from 18 months to 3 yrs	EW3AA5100
Extended warranty from 18 months to 5 yrs	EW5AA5100





## Support you can trust

At Edwards we pride ourselves on developing service solutions that deliver optimum performance and up-time to our customers. Convenience, quality and value are at the heart of everything we do. Whether you are looking for immediate help and advice or require a long-term total service partner, we make the performance of your business our priority.

## Well-Maintained Systems Last Longer

Maximise the lifetime of your product by servicing your own products regularly using original parts and tooling. Edwards can support you with spares, maintenance kits, tools and training. Combining the reliability of original spare parts with quality tools means you are well on the way to achieving years of trouble-free operation.

## Comprehensive Repair Solutions

When products require more than just routine maintenance, Edwards offer a complete suite of Repair, Overhaul and 'ReManufacturing' solutions. All are covered by the assurance of the manufacturer's guarantee. We offer a fixed price servicing for swift response and simple budgeting, or a more flexible pricing, structured to reflect the specific needs of the repair. All 'ReManufacturing' services are completed to the highest standards using the proven assembly and test procedures developed in our factories.

If turnaround is critical a service exchange product can usually be dispatched to you from local stock within hours.

## Effective Managed Maintenance

For any business the ability to plan ahead is key. Managed Maintenance is about easy access to the right services at the right time. Regular scheduled maintenance is crucial to identifying potential problems before they occur. Avoiding unplanned downtime is essential to achieving outstanding operational performance and lowering the total cost of ownership (TCO). Our qualified service engineers can help you monitor and maintain your vacuum system to avoid one-off costly repairs while managing service on a fixed budget as part of a Managed Maintenance agreement.

## Economy Without Compromise

'Edwards CERTIFIED' are genuine Edwards products 'ReManufactured' to provide a cost-effective route to expand, upgrade or replace your installations without compromising quality, reliability or performance. Like our service exchange product, 'Certified' products are tested as new and are supported by a 12 month warranty, and come with original accessories and manuals required to aid installation.

## Prolonged Peace Of Mind

Extending the new equipment warranty gives you a simple opportunity to add peace of mind to your purchase of new equipment, should a fault occur as a result of a manufacturing defect, equipment is expressly repaired or replaced. Cover is available on many of our products allowing the original factory warranty to be extended from 12 months to 2 years and beyond.

## Your Global Partner

We understand the importance of local support. Edwards has a number of major service facilities located throughout the world, each location is supported by an extensive team of engineers and technicians to provide local, rapid response and great value service. All our service operations are conducted at the highest international standards in accordance with ISO9001 (Quality), ISO14001 (Environmental), and OHSAS18001 (Workplace safety).





## Global contacts

Publication Number: 3601 0378 01.  
 © Edwards Limited 2018. All rights reserved  
 Edwards and the Edwards logo are trademarks of  
 Edwards Limited

Whilst we make every effort to ensure that we  
 accurately describe our products and services,  
 we give no guarantee as to the accuracy or  
 completeness of any information provided in  
 this brochure.

Edwards Ltd, registered in England and Wales  
 No. 6124750, registered office: Innovation Drive,  
 Burgess Hill, West Sussex, RH15 9TW, UK.

### EMEA

<b>UK</b>	+44 1444 253 000 (local rate) 08459 212223
<b>Belgium</b>	+32 2 300 0730
<b>France</b>	+33 1 4121 1256
<b>Germany</b>	0800 000 1456
<b>Italy</b>	+ 39 02 48 4471
<b>Israel</b>	+ 972 8 681 0633

### ASIA PACIFIC

<b>China</b>	+86 400 111 9618
<b>India</b>	+91 20 4075 2222
<b>Japan</b>	+81 47 458 8836
<b>Korea</b>	+82 31 716 7070
<b>Singapore</b>	+65 6546 8408
<b>Taiwan</b>	+886 3758 1000

### AMERICAS

<b>USA</b>	+1 800 848 9800
<b>Brazil</b>	+55 11 3952 5000